



01

PART ONE

自动平移门系列

Automatic Sliding Door Unit

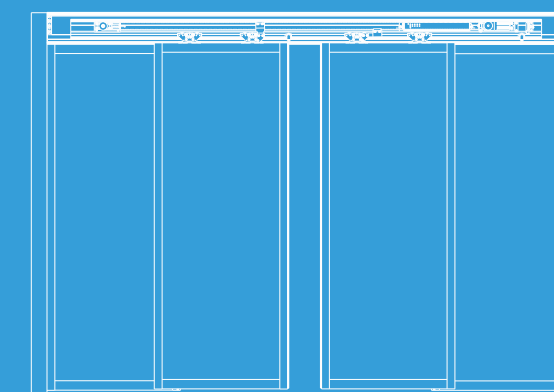

ORD-120 自动平移门机组

ORDstye Automatic Sliding Door

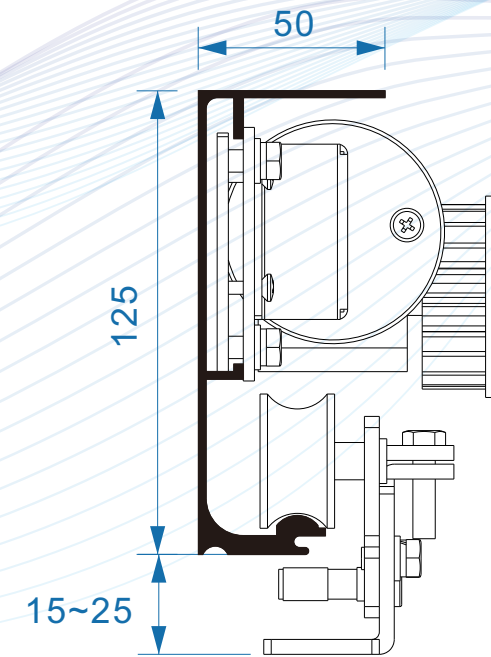
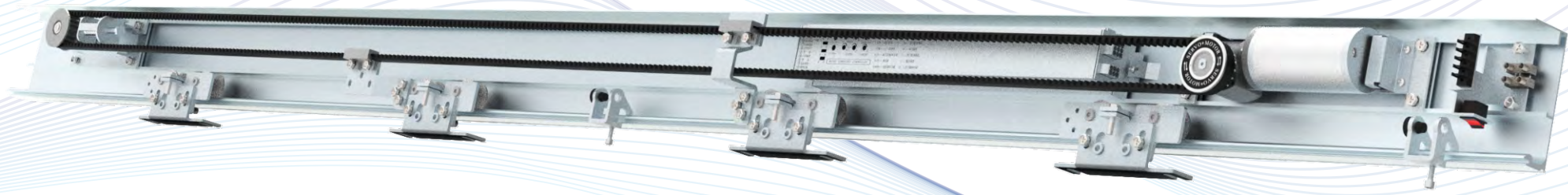

产品特点 PRODUCT PARAMETERS

全新控制器

控制器短款，增加安装空间的同时，遇阻反弹、门禁、电锁、电池、互锁等功能一应俱全，同时减小尺寸，适用场景更广。

全新吊件

松下H3通用款吊件，双防脱件设计，不脱轨。优质轴承轮，承重大。

安装调节空间加长

加长螺丝滑槽，安装调节提升至26mm

一体式驱动控制系统设计

驱动马达和控制器组成一个单元，全新电机，吊轮可以从电机下方通过。

NEW CONTROLLER

The controller is short, and although the sparrow is small and dirty, it bounces back when blocked. It has all the functions such as access control, electric lock, battery, and interlock, while reducing the size and increasing the installation space.

NEW HANGER

Panasonic H3 universal hanger, dual anti-derailment design, non-derailment. High quality bearing wheel with large bearing capacity.

EXTENDED INSTALLATION AND ADJUSTMENT SPACE

Extended screw chute, installation, adjustment and lifting to 26mm





DESIGN OF INTEGRATED DRIVE CONTROL SYSTEM

The drive motor and controller form a unit, a brand new motor, and the lifting wheel can pass under the motor.

技术参数 PRODUCT PARAMETERS

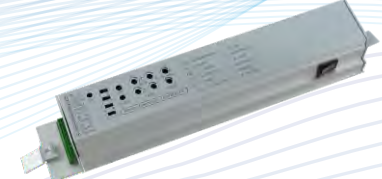
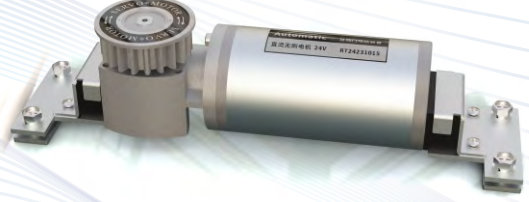
电气数据	Electrical data
电源电压: AC220V ± 10%, 50-60Hz 2A	Power supply voltage: AC220V ± 10%, 50-60Hz 2A
额定电压: 55W	Rated voltage: 55W
开口宽度	Opening width
双开平移门: 650~1250	Double sliding door: 65 ~ 1250
单开平移门: 750~1600	Single sliding door: 750 ~ 1600
门扇重量	Door leaf weight
双开平移门: 最大2×120KG	Double opening sliding door: max. 2 × 120KG
单开平移门: 最大1×220KG	Single sliding door: max. 1 × 220KG
门扇运行速度	Door leaf running speed
开门速度: 150~460mm/s	Opening speed: 150 ~ 460mm / S
关门速度: 150~460mm/s	Closing speed: 150 ~ 460mm / S
环境条件	Environment condition
温度范围: -20℃~+50℃	Temperature range: - 20 °C ~ + 50 °C
湿度范围: <相对湿度85%	Humidity range: < 85% relative humidity

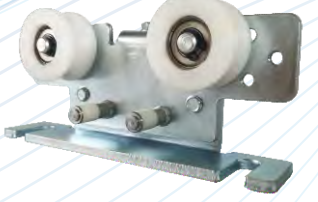
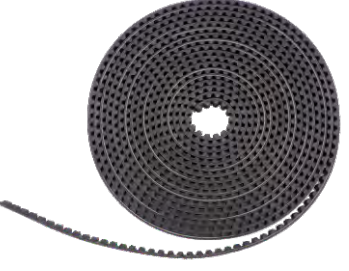
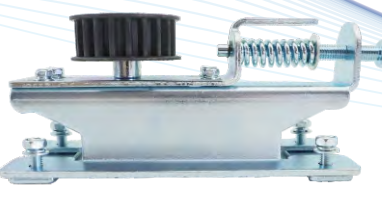
主要配件 MAIN ACCESSORIES

			
控制器 Controller	电机 Motor	轨道 track	吊轮 Hanger
			
皮带 Belt	尾轮 Pulley	限位器 Stopper	遥控器 remote control

可选配件 MAIN ACCESSORIES

				
防夹光线 Anti pinch equipment	影像感应器 Image sensor	门禁机 Access control machine	门夹 Door clip	备用电源 Backup

ORD-125A 自动平移门机组

ORD125A sty Automatic Sliding Door

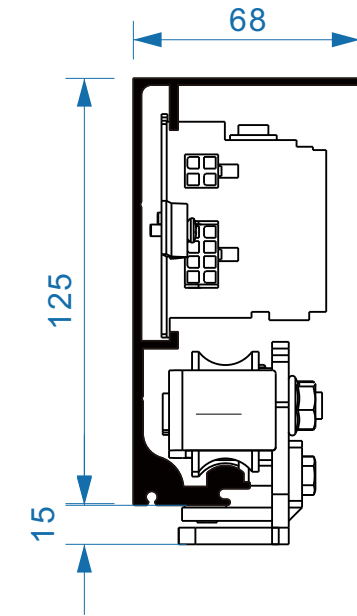

产品特点 PRODUCT PARAMETERS

全新控制器

控制器短款, 增加安装空间的同时, 遇阻反弹、门禁、电锁、电池、互锁等功能一应俱全, 同时减小尺寸, 适用场景更广。

全新吊件

松下H3通用款吊件, 双防脱件设计, 不脱轨。优质轴承轮, 承重大。

安装调节空间加长

加长螺丝滑槽, 安装调节提升至26mm

一体式驱动控制系统设计

驱动马达和控制器组成一个单元, 全新电机, 吊轮可以从电机下方通过。

NEW CONTROLLER

The controller is short, and although the sparrow is small and dirty, it bounces back when blocked.

It has all the functions such as acce-

-ss control, electric lock, battery, and interlock, while reducing the size and increasing the installation space.

NEW HANGER

Panasonic H3 universal hanger, dual anti derailment design, non derailment.

High quality bearing wheel with large bearing capacity.

EXTENDED INSTALLATION AND ADJUSTMENT SPACE

Extended screw chute, installation, adjustment and lifting to 26mm







DESIGN OF INTEGRATED DRIVE CONTROL SYSTEM

The drive motor and controller form a unit, a brand new motor, and the lifting wheel can pass under the motor.

技术参数 PRODUCT PARAMETERS

电气数据	Electrical data
电源电压: AC220V ± 10%, 50-60Hz 2A	Power supply voltage: AC220V ± 10%, 50-60Hz 2A
额定电压: 65W	Rated voltage: 65W
开口宽度	Opening width
双开平移门: 650~1250	Double sliding door: 65 ~ 1250
单开平移门: 750~1600	Single sliding door: 750 ~ 1600
门扇重量	Door leaf weight
双开平移门: 最大2×150KG	Double opening sliding door: max. 2 × 150KG
单开平移门: 最大1×250KG	Single sliding door: max. 1 × 250KG
门扇运行速度	Door leaf running speed
开门速度: 150~460mm/s	Opening speed: 150 ~ 460mm / S
关门速度: 150~460mm/s	Closing speed: 150 ~ 460mm / S
环境条件	Environment condition
温度范围: -20℃~+50℃	Temperature range: - 20 °C ~ + 50 °C
湿度范围: <相对湿度85%	Humidity range: < 85% relative humidity

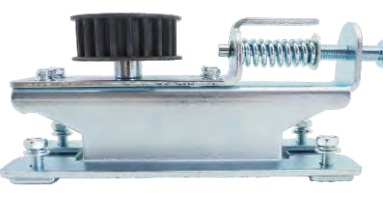
主要配件 MAIN ACCESSORIES

			
控制器 Controller	电机 Motor	轨道 track	吊轮 Hanger
			
皮带 Belt	尾轮 Pulley	限位器 Stopper	遥控器 remote control

可选配件 MAIN ACCESSORIES

				
防夹光线 Anti pinch equipment	影像感应器 Image sensor	门禁机 Access control machine	门夹 Door clip	备用电源 Backup

ORD-130 自动平移门机组

ORD130 sty Automatic Sliding Door



产品特点 PRODUCT PARAMETERS

全新控制器

控制器短款, 增加安装空间的同时, 遇阻反弹、门禁、电锁、电池、互锁等功能一应俱全, 同时减小尺寸, 适用场景更广。

全新吊件

松下H3通用款吊件, 双防脱件设计, 不脱轨。优质轴承轮, 承重大。

安装调节空间加长

加长螺丝滑槽, 安装调节提升至26mm

一体式驱动控制系统设计

驱动马达和控制器组成一个单元, 全新电机, 吊轮可以从电机下方通过。

NEW CONTROLLER

The controller is short, and although the sparrow is small and dirty, it bounces back when blocked. It has all the functions such as access control, electric lock, battery, and interlock, while reducing the size and increasing the installation space.

NEW HANGER

Panasonic H3 universal hanger, dual anti derailment design, non derailment. High quality bearing wheel with large bearing capacity.

EXTENDED INSTALLATION AND ADJUSTMENT SPACE

Extended screw chute, installation, adjustment and lifting to 26mm

DESIGN OF INTEGRATED DRIVE CONTROL SYSTEM



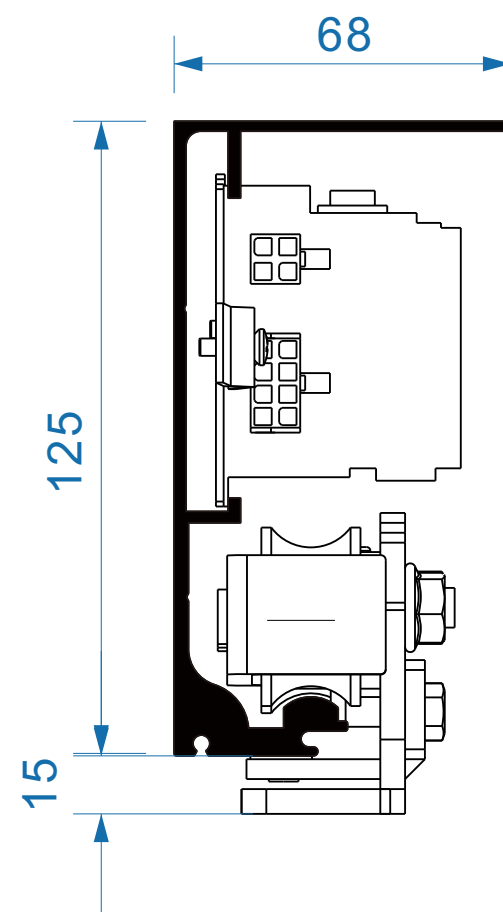



The drive motor and controller form a unit, a brand new motor, and the lifting wheel can pass under the motor.



技术参数 PRODUCT PARAMETERS

电气数据	Electrical data
电源电压: AC220V ± 10%, 50-60Hz 2A	Power supply voltage: AC220V ± 10%, 50-60Hz 2A
额定电压: 65W	Rated voltage: 65W
开口宽度	Opening width
双开平移门: 650~1250	Double sliding door: 65 ~ 1250
单开平移门: 750~1600	Single sliding door: 750 ~ 1600
门扇重量	Door leaf weight
双开平移门: 最大2 × 150KG	Double opening sliding door: max. 2 × 150KG
单开平移门: 最大1 × 260KG	Single sliding door: max. 1 × 260KG
门扇运行速度	Door leaf running speed
开门速度: 150~460mm/s	Opening speed: 150 ~ 460mm / S
关门速度: 150~460mm/s	Closing speed: 150 ~ 460mm / S
环境条件	Environment condition
温度范围: -20°C~+50°C	Temperature range: - 20 °C ~ + 50 °C
湿度范围: <相对湿度85%	Humidity range: < 85% relative humidity

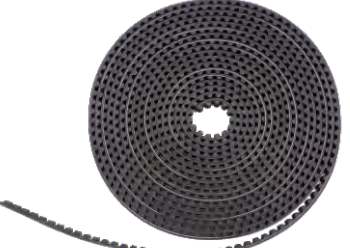
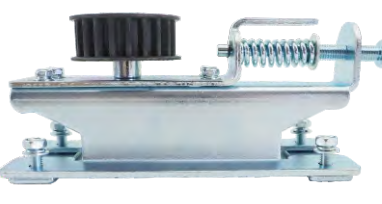
主要配件 MAIN ACCESSORIES

			
控制器 Controller	电机 Motor	轨道 track	吊轮 Hanger
			
皮带 Belt	尾轮 Pulley	限位器 Stopper	遥控器 remote control

可选配件 MAIN ACCESSORIES

				
防夹光线 Anti pinch equipment	影像感应器 Image sensor	门禁机 Access control machine	门夹 Door clip	备用电源 Backup

ORD-150 自动平移门机组

ORD150 sty Automatic Sliding Door



产品特点 PRODUCT PARAMETERS

微电脑控制器

微电脑控制系统,可控制门体按照设定的方式运行,实现双门互锁等多组接口,同时自带开机自检、遇阻反弹,防止夹伤人事故的发生。

减速箱一体化

采用欧洲马达设计,减速箱一体化技术,驱动强劲运行平稳,输出功率提高。

减速静音轮

特质减速静音轮,专业吊件设计,滚轮接口有效降低运行噪音。

多控制程序定制

可定制专业程序控制器,支持呆账,随意停,蓝牙,数控显等控制程序。

Microcomputer controller

Microcomputer control system, can control the door body in accordance with the set way to operate, to achieve double-door interlock Multiple groups of interfaces, at the same time with boot self-test, resistance rebound, to prevent the occurrence of nip accidents.

Reducer integration

European motor design, gearbox integration technology, drive strong and smooth operation, output power Raise.

Reduction mute wheel

Special deceleration silent wheel, professional lifting design, roller interface effectively reduce operating noise.

Multi-control program customization



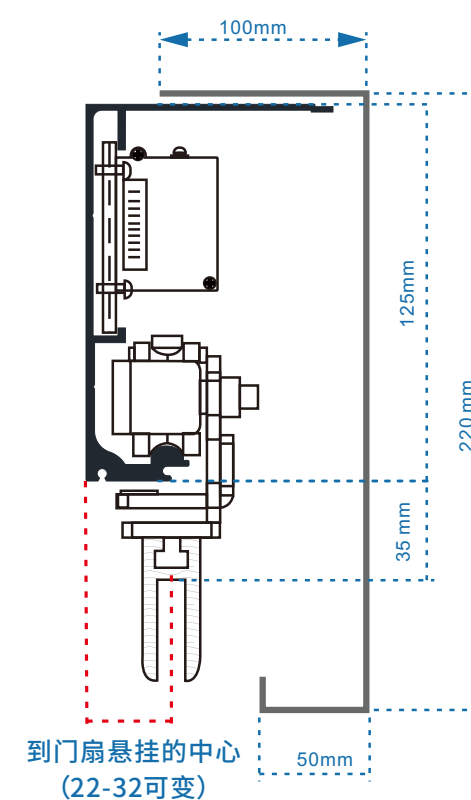

Professional program controller can be customized to support bad debts, random stop, Bluetooth, CNC display and other control programs.



技术参数 PRODUCT PARAMETERS

电气数据	Electrical data
电源电压: AC220V ± 10%, 50-60Hz 2A	Power supply voltage: AC220V ± 10%, 50-60Hz 2A
额定功率: 70W	Rated voltage: 70W
开口宽度	Opening width
双开平移门: 650~1250	Double sliding door: 650 ~ 1250
单开平移门: 750~1600	Single sliding door: 750 ~ 1600
门扇重量	Door leaf weight
双开平移门: 最大2×160KG	Double opening sliding door: max. 2 × 160KG
单开平移门: 最大1×270KG	Single sliding door: max. 1 × 270KG
门扇运行速度	Door leaf running speed
开门速度: 150~460mm/s	Opening speed: 150 ~ 460mm / S
关门速度: 150~460mm/s	Closing speed: 150 ~ 460mm / S
环境条件	Environment condition
温度范围: -20℃~+50℃	Temperature range: - 20 °C ~ + 50 °C
湿度范围: <相对湿度85%	Humidity range: < 85% relative humidity

主要配件 MAIN ACCESSORIES

			
控制器 Controller	电机 Motor	轨道 track	吊轮 Hanger
			
皮带 Belt	尾轮 Pulley	限位器 Stopper	遥控器 remote control

可选配件 MAIN ACCESSORIES

				
防夹光线 Anti pinch equipment	影像感应器 Image sensor	门禁机 Access control machine	门夹 Door clip	备用电源 Backup

ORD-160 自动平移门机组

ORD160 stye Automatic Sliding Door

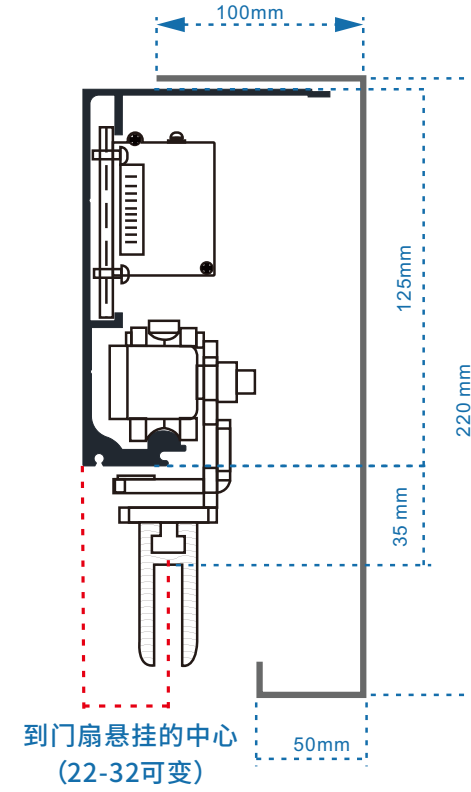
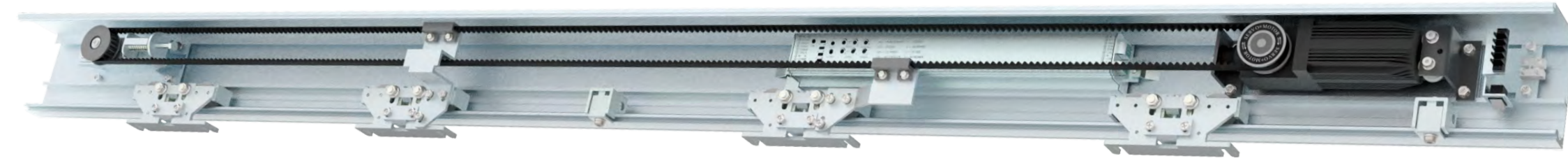

产品特点 PRODUCT PARAMETERS

微电脑控制器

微电脑控制系统,可控制门体按照设定的方式运行,实现双门互锁等多组接口,同时自带开机自检、遇阻反弹,防止夹伤人事故的发生。

减速箱一体化

采用欧洲马达设计,减速箱一体化技术,驱动强劲运行平稳,输出功率提高。

减速静音轮

特质减速静音轮,专业吊件设计,滚轮接口有效降低运行噪音。

多控制程序定制

可定制专业程序控制器,支持呆账,随意停,蓝牙,数控显等控制程序。

Microcomputer controller

The door body operates in a set manner, achieving multiple sets of interfaces such as double door interlocking, and also comes with a power on self-test and rebound when encountering obstacles Gearbox integration
Adopting European motor design and gearbox integration technology, the drive is strong and stable, with improved output power.

Decelerating mute wheel

Special decelerating silent wheel, professional suspension design, and roller interface effecti-vely reduce running noise.

Multi control program customization

Customizable professional program controller, supporting bad debt, random stop, Bluetooth and other control programs.

技术参数 PRODUCT PARAMETERS

电气数据	Electrical data
电源电压:AC220V±10%, 50-60Hz 2A	Power supply voltage: AC220V ± 10%, 50-60Hz 2A
额定功率:100W	Rated voltage: 100W
开口宽度	Opening width
双开平移门:650-1850	Double sliding door: 65 ~ 1850
单开平移门:750-2000	Single sliding door: 750 ~ 2000
门扇重量	Door leaf weight
双开平移门:最大2×180KG	Double opening sliding door: max. 2 × 180KG
单开平移门:最大1×300KG	Single sliding door: max. 1 × 300KG
门扇运行速度	Door leaf running speed
开门速度:150-460mm/s	Opening speed: 150 ~ 460mm / S
关门速度:150-460mm/s	Closing speed: 150 ~ 460mm / S
环境条件	Environment condition
温度范围:-20°C~+50°C	Temperature range: - 20 °C ~ + 50 °C
湿度范围:<相对湿度85%	Humidity range: < 85% relative humidity

主要配件 MAIN ACCESSORIES

控制器 Controller	电机 Motor	轨道 track	吊轮 Hanger
皮带 Belt	尾轮 Pulley	限位器 Stopper	遥控器 remote control

可选配件 MAIN ACCESSORIES

防夹光线 Anti pinch equipment	影像感应器 Image sensor	门禁机 Access control machine	门夹 Door clip	备用电源 Backup

ORD-180A 自动平移门机组

ORD180A sty Automatic Sliding Door



产品特点 PRODUCT PARAMETERS

全新轨道
超低轨道设计, 节省安装空间, 适合办公室、家庭阳台、厨房隔断、商铺等地方安装。同时轨道增加防震减噪静音胶条, 有效降低噪音。

全新吊件
吊轮采用三轮防脱设计, 轮径大, 加大机组承重能力, 防脱落, 安全性高。

欧款机组设计, 美观大气
独有的备用电池系统, 可实现断电开门和正常运行自由切换, 无论是消防功能还是防盗功能, 都能完美切换。

一体式驱动控制系统设计
驱动马达和控制器组成一个单元, 全新电机, 吊轮可以从电机下方通过。

控制器程序可定制
为满足不同场景下不同自动门需要的功能, 该款自动门机组支持程序定制。

New track
Low height rail design, saving installation space, suitable for installation in offices, kitchen partitions, shops and other places.

New hanger
The hanging wheel is designed with three wheels to prevent falling off. The diameter of the wheel is large, which increases the bearing capacity of the unit, prevents falling off and has high safety.

Fire fighting and anti-theft functions can be switched freely
The unique backup battery system can realize the free switching of power-off, door opening and normal operation. It can perfectly switch the fire-fighting function and anti-theft function.

Design of integrated drive control system
The drive motor and the controller form a unit, which is a brand-new motor. The hanging wheel can pass under the motor.

技术参数 PRODUCT PARAMETERS

电气数据	Electrical data
电源电压: AC220V ± 10%, 50-60Hz 2A	Power supply voltage: AC220V ± 10%, 50-60Hz 2A
额定功率: 70W	Rated voltage: 70W
开口宽度	Opening width
双开平移门: 1000-2700	Double sliding door: 1000 ~ 2700
单开平移门: 1000-2700	Single sliding door: 1000 ~ 2700
门扇重量	Door leaf weight
双开平移门: 最大2 × 200KG	Double opening sliding door: max. 2 × 200KG
单开平移门: 最大1 × 300KG	Single sliding door: max. 1 × 300KG
门扇运行速度	Door leaf running speed
开门速度: 300-550mm/s	Opening speed: 300 ~ 550mm / S
关门速度: 150-460mm/s	Closing speed: 150 ~ 460mm / S
环境条件	Environment condition
温度范围: -20°C ~ +50°C	Temperature range: - 20 °C ~ + 50 °C
湿度范围: < 相对湿度85%	Humidity range: < 85% relative humidity

主要配件 MAIN ACCESSORIES

			
控制器 Controller	电机 Motor	轨道 track	吊轮 Hanger
			
皮带 Belt	尾轮 Pulley	限位器 Stopper	遥控器 remote control

可选配件 MAIN ACCESSORIES

				
防夹光线 Anti pinch equipment	影像感应器 Image sensor	门禁机 Access control machine	门夹 Door clip	备用电源 Backup

ORD-180 自动平移门机组

ORD180stye Automatic Sliding Door

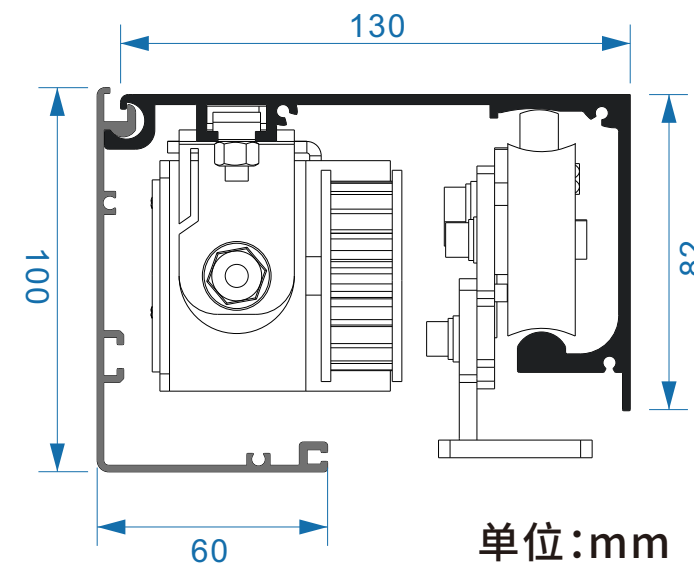

产品特点 PRODUCT PARAMETERS

全新轨道
超低轨道设计, 节省安装空间, 适合办公室、家庭阳台、厨房隔断、商铺等地方安装。同时轨道增加防震减噪静音胶条, 有效降低噪音。

全新吊件
吊轮采用三轮防脱设计, 轮径大, 加大机组承重能力, 防脱落, 安全性高。

欧款机组设计, 美观大气
独有的备用电池系统, 可实现断电开门和正常运行自由切换, 无论是消防功能还是防盗功能, 都能完美切换。

一体式驱动控制系统设计
驱动马达和控制器组成一个单元, 全新电机, 吊轮可以从电机下方通过。

控制器程序可定制
为满足不同场景下不同自动门需要的功能, 该款自动门机组支持程序定制。

New track
Low height rail design, saving installation space, suitable for installation in offices, kitchen partitions, shops and other places.

New hanger
The hanging wheel is designed with three wheels to prevent falling off. The diameter of the wheel is large, which increases the bearing capacity of the unit, prevents falling off and has high safety.







Fire fighting and anti-theft functions can be switched freely
The unique backup battery system can realize the free switching of power-off, door opening and normal operation. It can perfectly switch the fire-fighting function and anti-theft function.

Design of integrated drive control system
The drive motor and the controller form a unit, which is a brand-new motor. The hanging wheel can pass under the motor.

技术参数 PRODUCT PARAMETERS

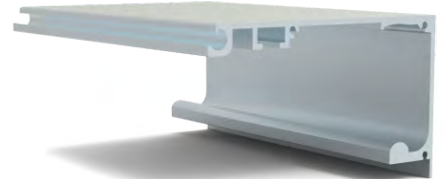
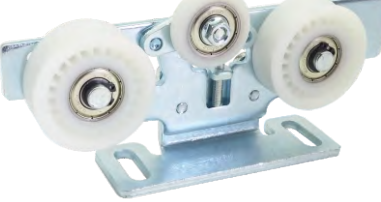
电气数据	Electrical data
电源电压: AC220V ± 10%, 50-60Hz 2A	Power supply voltage: AC220V ± 10%, 50-60Hz 2A
额定功率: 70W	Rated voltage: 70W
开口宽度	Opening width
双开平移门: 1000-2700	Double sliding door: 1000 ~ 2700
单开平移门: 1000-2700	Single sliding door: 1000 ~ 2700
门扇重量	Door leaf weight
双开平移门: 最大2 × 180KG	Double opening sliding door: max. 2 × 180KG
单开平移门: 最大1 × 300KG	Single sliding door: max. 1 × 300KG
门扇运行速度	Door leaf running speed
开门速度: 300-550mm/s	Opening speed: 300 ~ 550mm / S
关门速度: 150-460mm/s	Closing speed: 150 ~ 460mm / S
环境条件	Environment condition
温度范围: -20°C ~ +50°C	Temperature range: - 20 °C ~ + 50 °C
湿度范围: <相对湿度85%	Humidity range: < 85% relative humidity

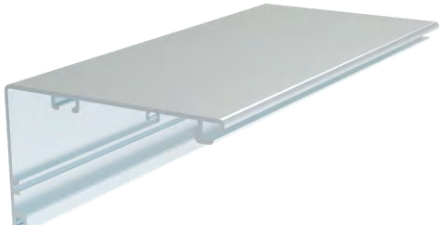
主要配件 MAIN ACCESSORIES

			
控制器 Controller	电机 Motor	轨道 track	吊轮 Hanger
			
皮带 Belt	尾轮 Pulley	盖板 Cover plate	遥控器 remote control

可选配件 MAIN ACCESSORIES

				
防夹光线 Anti pinch equipment	影像感应器 Image sensor	门禁机 Access control machine	门夹 Door clip	备用电源 Backup

ORD-200 自动平移门机组

ORD200 sty Automatic Sliding Door

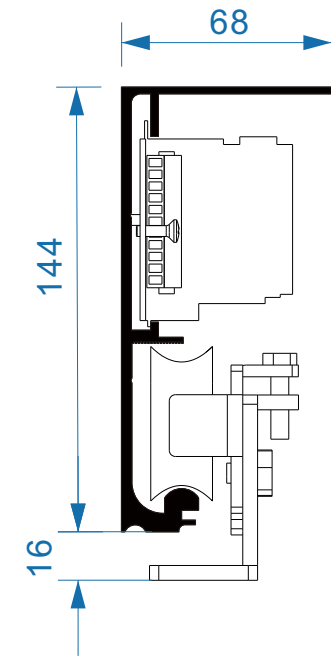
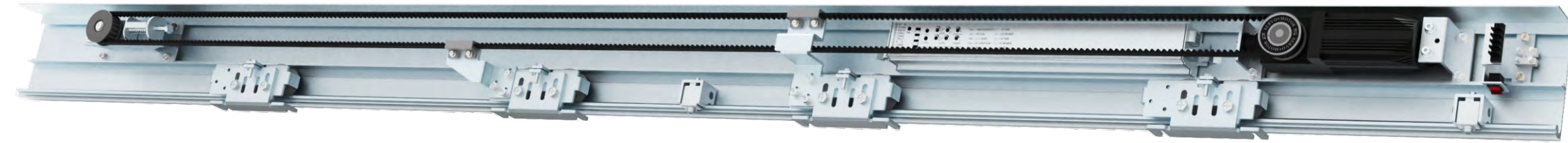

产品特点 PRODUCT PARAMETERS

微电脑控制器

微电脑控制系统,可控制门体按照设定的方式运行,实现双门互锁等多组接口,同时自带开机自检、遇阻反弹,防止夹伤人事故的发生。

减速箱一体化

采用欧洲马达设计,减速箱一体化技术,驱动强劲运行平稳,输出功率提高。

减速静音轮

特质减速静音轮,专业吊件设计,滚轮接口有效降低运行噪音。

多控制程序定制

可定制专业程序控制器,支持呆账,随意停,蓝牙,数控显等控制程序。

Microcomputer controller

Microcomputer control system, can control the door body in accordance with the set way to operate, to achieve double-door interlock Multiple groups of interfaces, at the same time with boot self-test, resistance rebound, to prevent the occurrence of nip accidents.

Reducer integration

European motor design, gearbox integration technology, drive strong and smooth operation, output power Raise.

Reduction mute wheel

Special deceleration silent wheel, professional lifting design, roller interface effectively reduce operating noise.







Multi-control program customization

Professional program controller can be customized to support bad debts, random stop, Bluetooth, CNC display and other control programs.

技术参数 PRODUCT PARAMETERS

电气数据	Electrical data
电源电压:AC220V±10%, 50-60Hz 2A	Power supply voltage: AC220V ± 10%, 50-60Hz 2A
额定功率:100W	Rated voltage: 100W
开口宽度	Opening width
双开平移门:1000-2700	Double sliding door: 1000 ~ 2700
单开平移门:1000-2700	Single sliding door: 1000 ~ 2700
门扇重量	Door leaf weight
双开平移门:最大2×180KG	Double opening sliding door: max. 2 × 180KG
单开平移门:最大1×300KG	Single sliding door: max. 1 × 300KG
门扇运行速度	Door leaf running speed
开门速度:300-550mm/s	Opening speed: 300 ~ 550mm / S
关门速度:150-460mm/s	Closing speed: 150 ~ 460mm / S
环境条件	Environment condition
温度范围:-20°C~+50°C	Temperature range: - 20 °C ~ + 50 °C
湿度范围:<相对湿度85%	Humidity range: < 85% relative humidity

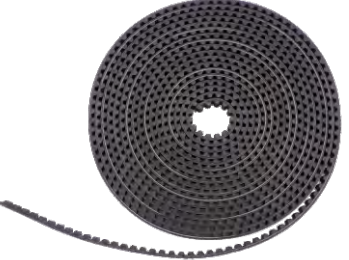
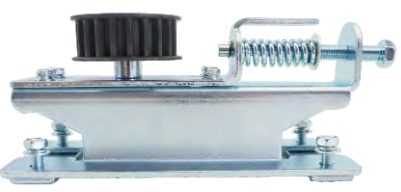
主要配件 MAIN ACCESSORIES

			
控制器 Controller	电机 Motor	轨道 track	吊轮 Hanger
			
皮带 Belt	尾轮 Pulley	限位器 Stopper	遥控器 remote control

可选配件 MAIN ACCESSORIES

				
防夹光线 Anti pinch equipment	影像感应器 Image sensor	门禁机 Access control machine	门夹 Door clip	备用电源 Backup

ORD-230A 自动平移门机组

ORD230 sty Automatic Sliding Door

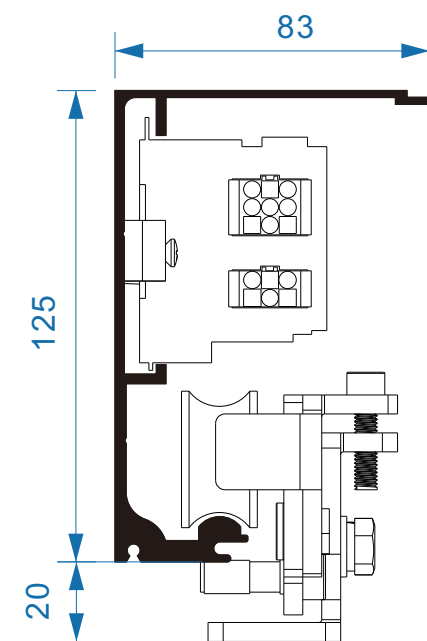

产品特点 PRODUCT PARAMETERS

微电脑控制器

微电脑控制系统,可控制门体按照设定的方式运行,实现双门互锁等多组接口,同时自带开机自检、遇阻反弹,防止夹伤人事故的发生。

减速箱一体化

采用欧洲马达设计,减速箱一体化技术,驱动强劲运行平稳,输出功率提高。

减速静音轮

特质减速静音轮,专业吊件设计,滚轮接口有效降低运行噪音。

多控制程序定制

可定制专业程序控制器,支持呆账,随意停,蓝牙,数控显等控制程序。

Microcomputer controller

Microcomputer control system, can control the door body in accordance with the set way to operate, to achieve double-door interlock Multiple groups of interfaces, at the same time with boot self-test, resistance rebound, to prevent the occurrence of nip accidents.

Reducer integration

European motor design, gearbox integration technology, drive strong and smooth operation, output power Raise.

Reduction mute wheel

Special deceleration silent wheel, professional lifting design, roller interface effectively reduce operating noise.









Multi-control program customization

Professional program controller can be customized to support bad debts, random stop, Bluetooth, CNC display and other control programs.

技术参数 PRODUCT PARAMETERS

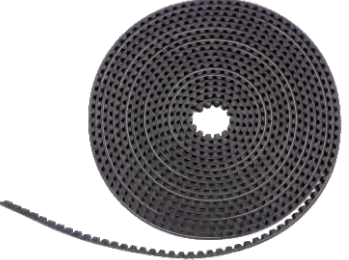
电气数据	Electrical data
电源电压:AC220V±10%, 50-60Hz 2A	Power supply voltage: AC220V ± 10%, 50-60Hz 2A
额定功率:100W	Rated voltage: 100W
开口宽度	Opening width
双开平移门:1000-2700	Double sliding door: 1000 ~ 2700
单开平移门:1000-2700	Single sliding door: 1000 ~ 2700
门扇重量	Door leaf weight
双开平移门:最大2×200KG	Double opening sliding door: max. 2 × 200KG
单开平移门:最大1×300KG	Single sliding door: max. 1 × 300KG
门扇运行速度	Door leaf running speed
开门速度:300-550mm/s	Opening speed: 300 ~ 550mm / S
关门速度:150-460mm/s	Closing speed: 150 ~ 460mm / S
环境条件	Environment condition
温度范围:-20°C~+50°C	Temperature range: - 20 °C ~ + 50 °C
湿度范围:<相对湿度85%	Humidity range: < 85% relative humidity

主要配件 MAIN ACCESSORIES

			
控制器 Controller	电机 Motor	轨道 track	吊轮 Hanger
			
皮带 Belt	尾轮 Pulley	限位器 Stopper	遥控器 remote control

可选配件 MAIN ACCESSORIES

				
防夹光线 Anti pinch equipment	影像感应器 Image sensor	门禁机 Access control machine	门夹 Door clip	备用电源 Backup

ORD-230B 自动平移门机组

ORD230 stye Automatic Sliding Door

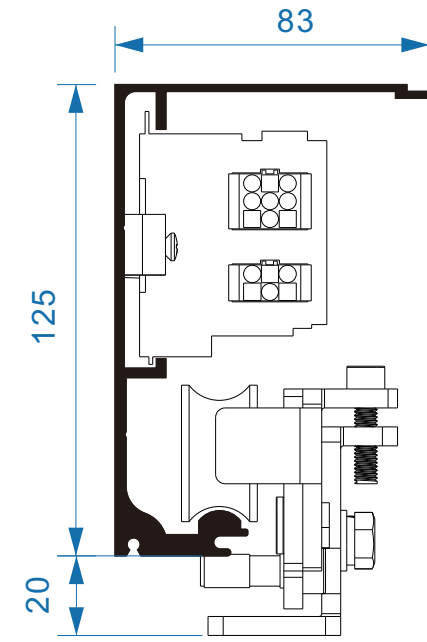

产品特点 PRODUCT PARAMETERS

微电脑控制器

微电脑控制系统,可控制门体按照设定的方式运行,实现双门互锁等多组接口,同时自带开机自检、遇阻反弹,防止夹伤人事故的发生。

减速箱一体化

采用欧洲马达设计,减速箱一体化技术,驱动强劲运行平稳,输出功率提高。

减速静音轮

特质减速静音轮,专业吊件设计,滚轮接口有效降低运行噪音。

多控制程序定制

可定制专业程序控制器,支持呆账,随意停,蓝牙,数控显等控制程序。

Microcomputer controller

Microcomputer control system, can control the door body in accordance with the set way to operate, to achieve double-door interlock Multiple groups of interfaces, at the same time with boot self-test, resistance rebound, to prevent the occurrence of nip accidents.

Reducer integration

European motor design, gearbox integration technology, drive strong and smooth operation, output power Raise.

Reduction mute wheel

Special deceleration silent wheel, professional lifting design, roller interface effectively reduce operating noise.









Multi-control program customization

Professional program controller can be customized to support bad debts, random stop, Bluetooth, CNC display and other control programs.

技术参数 PRODUCT PARAMETERS

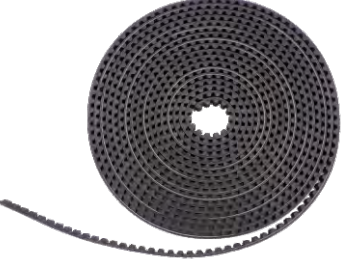
电气数据	Electrical data
电源电压:AC220V±10%, 50-60Hz 2A	Power supply voltage: AC220V ± 10%, 50-60Hz 2A
额定功率:100W	Rated voltage: 100W
开口宽度	Opening width
双开平移门:1000-2700	Double sliding door: 1000 ~ 2700
单开平移门:1000-2700	Single sliding door: 1000 ~ 2700
门扇重量	Door leaf weight
双开平移门:最大2×200KG	Double opening sliding door: max. 2 × 200KG
单开平移门:最大1×230KG	Single sliding door: max. 1 × 230KG
门扇运行速度	Door leaf running speed
开门速度:300-550mm/s	Opening speed: 300 ~ 550mm / S
关门速度:150-460mm/s	Closing speed: 150 ~ 460mm / S
环境条件	Environment condition
温度范围:-20°C~+50°C	Temperature range: - 20 °C ~ + 50 °C
湿度范围:<相对湿度85%	Humidity range: < 85% relative humidity

主要配件 MAIN ACCESSORIES

			
控制器 Controller	电机 Motor	轨道 track	吊轮 Hanger
			
皮带 Belt	尾轮 Pulley	限位器 Stopper	遥控器 remote control

可选配件 MAIN ACCESSORIES

				
防夹光线 Anti pinch equipment	影像感应器 Image sensor	门禁机 Access control machine	门夹 Door clip	备用电源 Backup

ORD-260 自动平移门机组

ORD260 sty Automatic Sliding Door

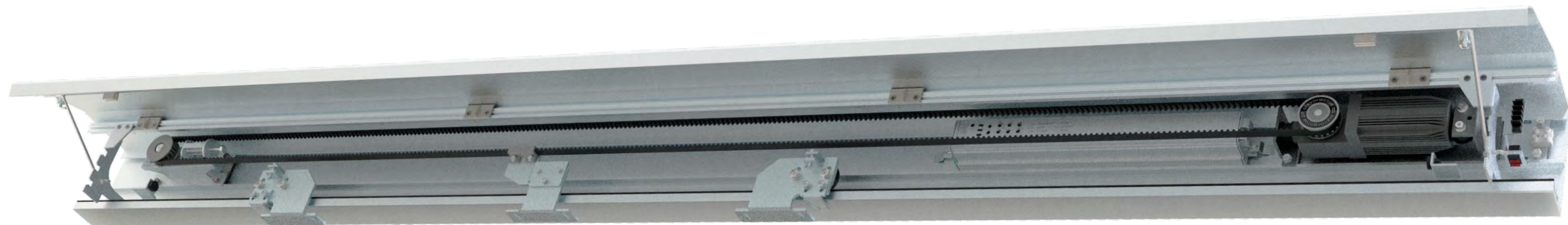

产品特点 PRODUCT PARAMETERS

门体形式:单开门/双开门
 门体重量: $\leq 1 \times 300\text{KG}$ / $\leq 2 \times 180\text{KG}$
 净开宽度:1000-2700mm/2200-3800mm
 电源电压:AC220V $\pm 10\%$, 50-60Hz
 功率消耗:70W
 开门运行速度:300-550mm/s(可调)
 关门运行速度:200-500mm/s(可调)
 开门停留时间:1-10s(可调)
 紧闭力F: $> 100\text{N}$
 手动推力: $< 100\text{N}$
 运行噪音: $\leq 55\text{Db}$
 工作环境温度:-20~+50°C



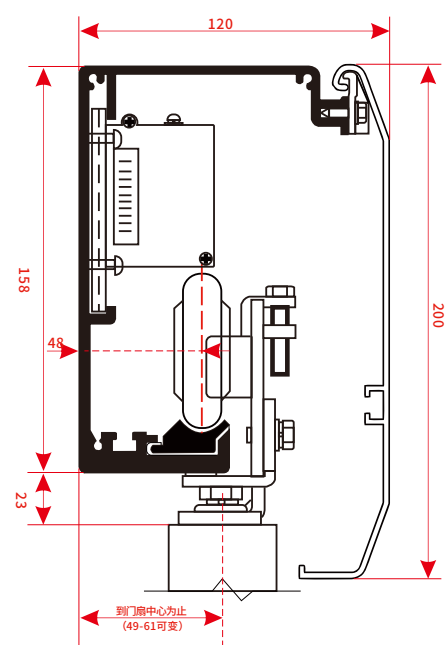

Door configuration :Four-leaf/Two-leaf
 Door leaf weight: $\leq 1 \times 300\text{KG}$ / $\leq 2 \times 180\text{KG}$
 Clean open width: 1000-2700mm/2200-3800mm
 Power voltage:AC220V $\pm 10\%$, 50-60Hz
 AC110V $\pm 10\%$, 50-60Hz
 Power consumption:70W
 Opening speed:300-550mm/s(adjustable)
 Closing speed:200-550mm/s(adjustable)
 Hold-open time:1-10s(adjustable)
 Closed force F: $> 100\text{N}$
 Manual push: $< 100\text{N}$
 Working environment temperature:-20~+50°C

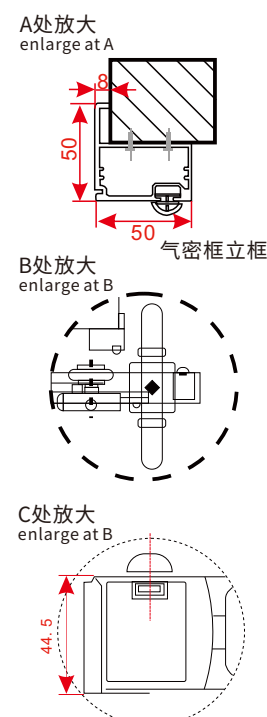
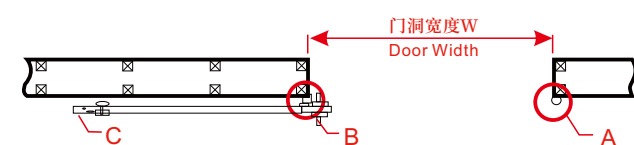
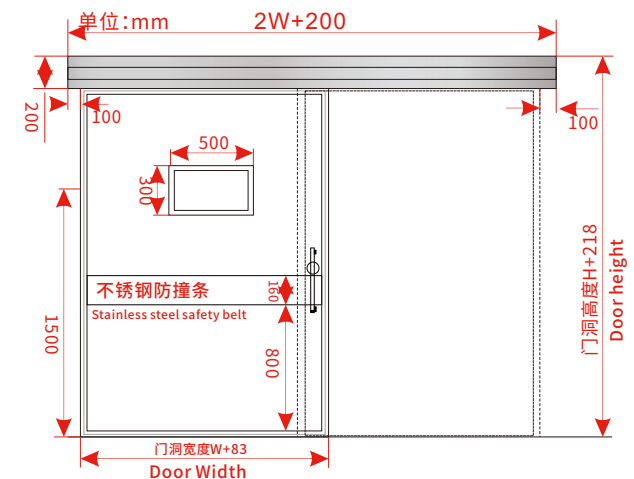

设备尺寸 EQUIPMENT SIZE

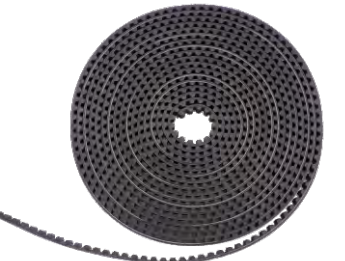
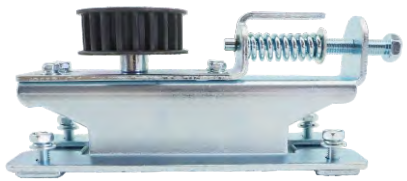

主要配件 MAIN ACCESSORIES

			
控制器 Controller	电机 Motor	轨道 track	吊轮 Hanger
			
皮带 Belt	尾轮 Pulley	限位器 Stopper	遥控器 remote control

可选配件 MAIN ACCESSORIES

				
防夹光线 Anti pinch equipment	影像感应器 Image sensor	门禁机 Access control machine	门夹 Door clip	备用电源 Backup

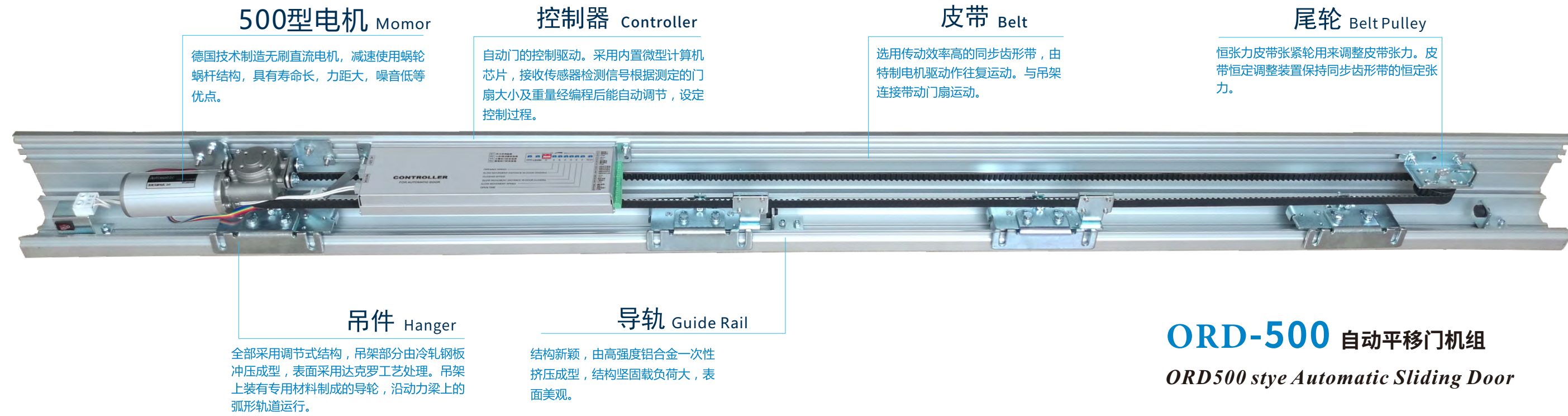

ORD-500 自动平移门机组
ORD500 sty Automatic Sliding Door

产品特点 PRODUCT PARAMETERS

- 1.直流无刷大功率电机，运行稳定；
- 2.大闭合力微电脑控制器；
- 3.大承重轨道装置，适合门体300KG；
- 4.轨道自带缓冲条，静音运行；
- 5.四种开门模式；常开、常闭、半开、自动；
- 6.自带遇阻反弹，安全防夹。

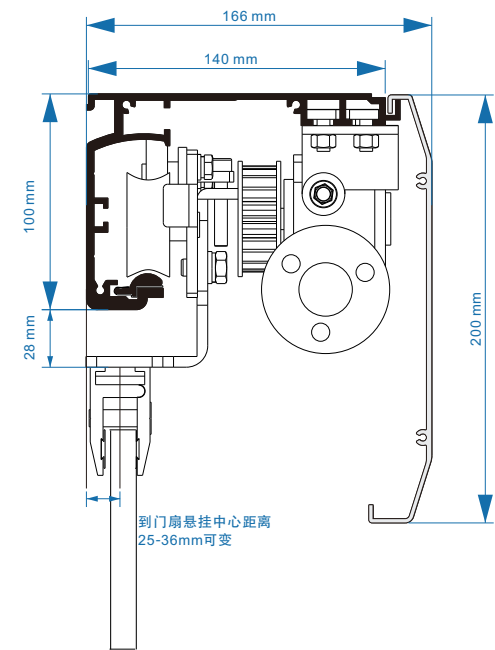

1. Dc brushless high-power motor, stable operation;
2. Large closing force microcomputer controller;
3. Large bearing track device, suitable for door body 300KG;
4. Track comes with buffer strip, silent operation;
5. Four modes of opening doors; Normally open, normally closed, semi-open, automatic;
6. Come with resistance rebound, safety anti-clip

技术参数 PRODUCT PARAMETERS

电气数据	Electrical data
电源电压:AC220V±10%, 50-60Hz 2A	Power supply voltage: AC220V ± 10%, 50-60Hz 2A
额定功率:100W	Rated voltage: 100W
开口宽度	Opening width
双开平移门:650~1250	Double sliding door: 650 ~ 1250
单开平移门:750~1600	Single sliding door: 750 ~ 1600
门扇重量	Door leaf weight
双开平移门:最大2×250KG	Double opening sliding door: max. 2 × 250KG
单开平移门:最大1×350KG	Single sliding door: max. 1 × 350KG
门扇运行速度	Door leaf running speed
开门速度:150~460mm/s	Opening speed: 150 ~ 460mm / S
关门速度:150~460mm/s	Closing speed: 150 ~ 460mm / S
环境条件	Environment condition
温度范围:-20°C~+50°C	Temperature range: - 20 °C ~ + 50 °C
湿度范围:<相对湿度85%	Humidity range: < 85% relative humidity

主要配件 MAIN ACCESSORIES

控制器 Controller	电机 Motor	轨道 track	吊轮 Hanger
皮带 Belt	尾轮 Pulley	限位器 Stopper	遥控器 remote control

可选配件 MAIN ACCESSORIES

防夹光线 Anti pinch equipment	影像感应器 Image sensor	门禁机 Access control machine	门夹 Door clip	备用电源 Backup

ORD-600A 自动平移门机组

ORD600A sty Automatic Sliding Door

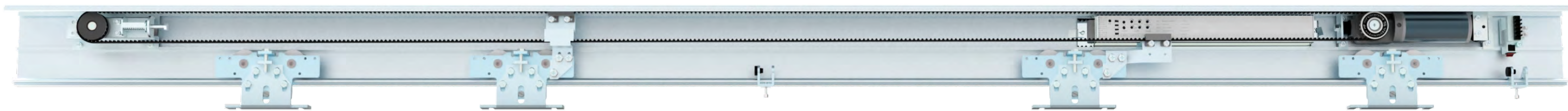

产品特点 PRODUCT PARAMETERS

1. 控制器采用进口双ST芯片, 内置自动校准和保护程序, 智能调节, 自动识别门体宽度, 抗信号干扰, 双向遇阻自动反弹, 安全性能更加突出。
2. 采用实测100W大功率直流无刷电机, 力矩大、寿命长、效率高。减速箱使用斜齿轮设计, 整体运行平稳, 具有自带锁功能, 无需外加机械锁就能实现门禁效果。
3. 使用重型机吊轮设计, 吊件采用优质轴承, 并使用50mm大号尼龙轮, 承重大、声音轻。
4. 新型铝合金轨道设计, 采用3.4mm厚壁铝合金, 承重更大, 声音更轻, 同时轨道含槽口, 支持加装铝合金盖板和封头, 节省折不锈钢的烦恼。
5. 自动门程序支持定制。

1. The controller adopts imported double st chip, built-in automatic calibration and protection program, intelligent adjustment, automatic identification of door width, anti signal interference, two-way automatic rebound when encountering resistance, and more outstanding safety performance.
2. The measured 100W high-power DC brushless motor is adopted, with large torque, long service life and high efficiency. With its own lock function, it can achieve the access control effect without adding a mechanical lock.
3. The lifting wheel of heavy-duty machine is designed. The lifting parts are high-quality bearings and 50mm large nylon wheels are used. Large load bearing and light sound.
4. The new aluminum alloy track is designed with 3.4mm thick wall aluminum alloy, which has greater bearing capacity and lighter sound. At the same time, the track contains notches, which supports the installation of aluminum alloy cover plates and heads.
5. Automatic door program supports customization.

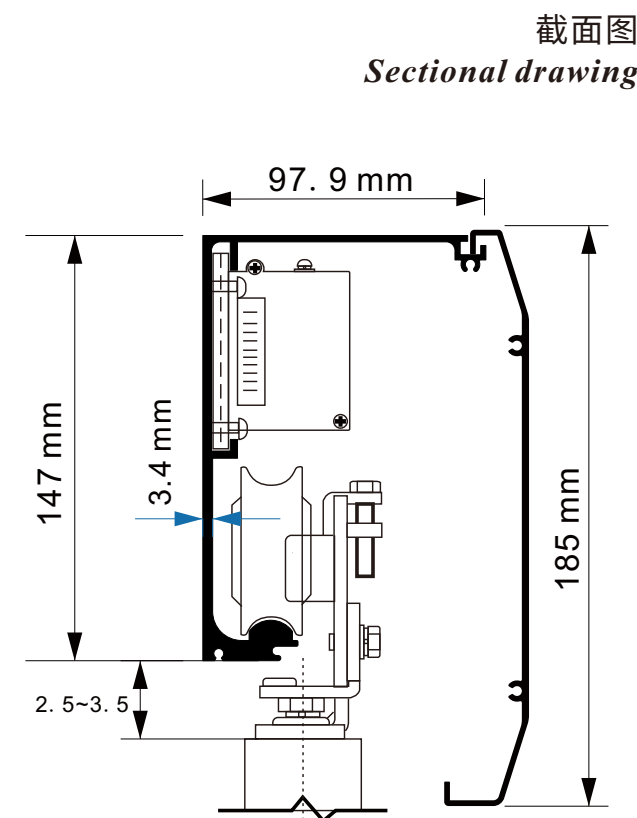

技术参数 PRODUCT PARAMETERS

电气数据	Electrical data
电源电压: AC220V±10%, 50-60Hz 2A	Power supply voltage: AC220V ± 10%, 50-60Hz 2A
额定功率: 100W	Rated power: 100W
开口宽度	Opening width
双开平移门: 1000~2700	Double sliding door: 1000 ~ 2700
单开平移门: 1000~2700	Single sliding door: 1000 ~ 2700
门扇重量	Door leaf weight
双开平移门: 最大2×250KG	Double opening sliding door: max. 2 × 250KG
单开平移门: 最大1×350KG	Single sliding door: max. 1 × 350KG
门扇运行速度	Door leaf running speed
开门速度: 300~550mm/s	Opening speed: 300 ~ 550mm / S
关门速度: 150~460mm/s	Closing speed: 150 ~ 460mm / S
环境条件	Environment condition
温度范围: -20℃~+50℃	Temperature range: - 20 °C ~ + 50 °C
湿度范围: <相对湿度85%	Humidity range: < 85% relative humidity

主要配件 MAIN ACCESSORIES

			
控制器 Controller	电机 Motor	轨道 track	吊轮 Hanger
			
皮带 Belt	尾轮 Pulley	限位器 Stopper	遥控器 remote control

可选配件 MAIN ACCESSORIES

				
防夹光线 Anti pinch equipment	影像感应器 Image sensor	门禁机 Access control machine	门夹 Door clip	备用电源 Backup

ORD-600B 自动平移门机组

ORD600B sty Automatic Sliding Door

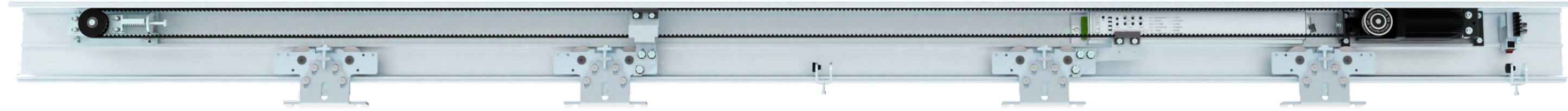

产品特点 PRODUCT PARAMETERS

1. 控制器采用进口双ST芯片, 内置自动校准和保护程序, 智能调节, 自动识别门体宽度, 抗信号干扰, 双向遇阻自动反弹, 安全性能更加突出。
2. 采用实测100W大功率直流无刷电机, 力矩大、寿命长、效率高。减速箱使用斜齿轮设计, 整体运行平稳, 具有自带锁功能, 无需外加机械锁就能实现门禁效果。
3. 使用重型机吊轮设计, 吊件采用优质轴承, 并使用50mm大号尼龙轮, 承重大、声音轻。
4. 新型铝合金轨道设计, 采用3.4mm厚壁铝合金, 承重更大, 声音更轻, 同时轨道含槽口, 支持加装铝合金盖板和封头, 节省折不锈钢的烦恼。
5. 自动门程序支持定制。

1. The controller adopts imported double st chip, built-in automatic calibration and protection program, intelligent adjustment, automatic identification of door width, anti signal interference, two-way automatic rebound when encountering resistance, and more outstanding safety performance.
2. The measured 100W high-power DC brushless motor is adopted, with large torque, long service life and high efficiency. With its own lock function, it can achieve the access control effect without adding a mechanical lock.
3. The lifting wheel of heavy-duty machine is designed. The lifting parts are high-quality bearings and 50mm large nylon wheels are used. Large load bearing and light sound.
4. The new aluminum alloy track is designed with 3.4mm thick wall aluminum alloy, which has greater bearing capacity and lighter sound. At the same time, the track contains notches, which supports the installation of aluminum alloy cover plates and heads.
5. Automatic door program supports customization.

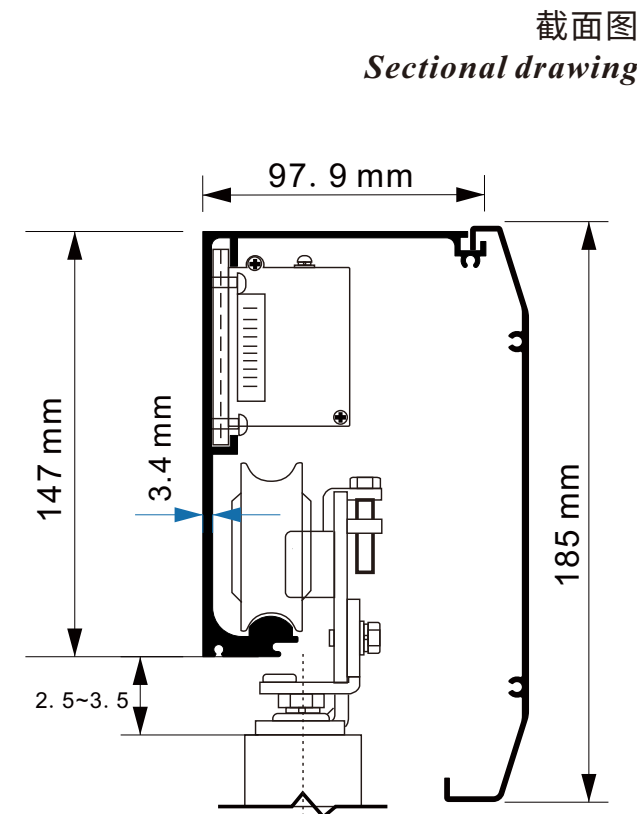

技术参数 PRODUCT PARAMETERS

电气数据	Electrical data
电源电压: AC220V±10%, 50-60Hz 2A	Power supply voltage: AC220V ± 10%, 50-60Hz 2A
额定功率: 100W	Rated voltage: 100W
开口宽度	Opening width
双开平移门: 1000~2700	Double sliding door: 1000 ~ 2700
单开平移门: 1000~2700	Single sliding door: 1000 ~ 2700
门扇重量	Door leaf weight
双开平移门: 最大2×250KG	Double opening sliding door: max. 2 × 250KG
单开平移门: 最大1×300KG	Single sliding door: max. 1 × 300KG
门扇运行速度	Door leaf running speed
开门速度: 300~550mm/s	Opening speed: 300 ~ 550mm / S
关门速度: 150~460mm/s	Closing speed: 150 ~ 460mm / S
环境条件	Environment condition
温度范围: -20℃~+50℃	Temperature range: - 20 °C ~ + 50 °C
湿度范围: <相对湿度85%	Humidity range: < 85% relative humidity

主要配件 MAIN ACCESSORIES

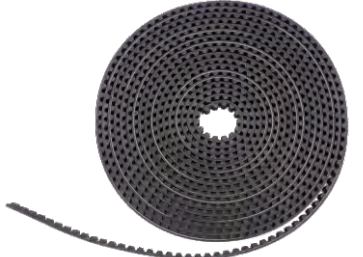
			
控制器 Controller	电机 Motor	轨道 track	吊轮 Hanger
			
皮带 Belt	尾轮 Pulley	限位器 Stopper	遥控器 remote control

可选配件 MAIN ACCESSORIES

				
防夹光线 Anti pinch equipment	影像感应器 Image sensor	门禁机 Access control machine	门夹 Door clip	备用电源 Backup

ORD-600S 自动平移门机组

ORD600S sty Automatic Sliding Door



产品特点 PRODUCT PARAMETERS

- 智能控制系统, 自动调节门叶的运行状态启动时, 自动学习开始, 根据实际门宽尺寸自动调整参数, 以达到最佳运行条件, 必要时可进行手动调整。
- 无刷电机(BLDC), 摩擦低, 寿命长。
- 门叶悬架采用自平衡和可靠的防脱设计, 使门叶运行更加平稳、安全、噪音低, 延长了悬架轮的使用寿命。
- 独特的电锁功能, 安全可靠, 双门互锁和电子锁功能, 支持多种门禁系统。
- 可以配备备用电源, 在停电的情况下可以保持门的开闭。



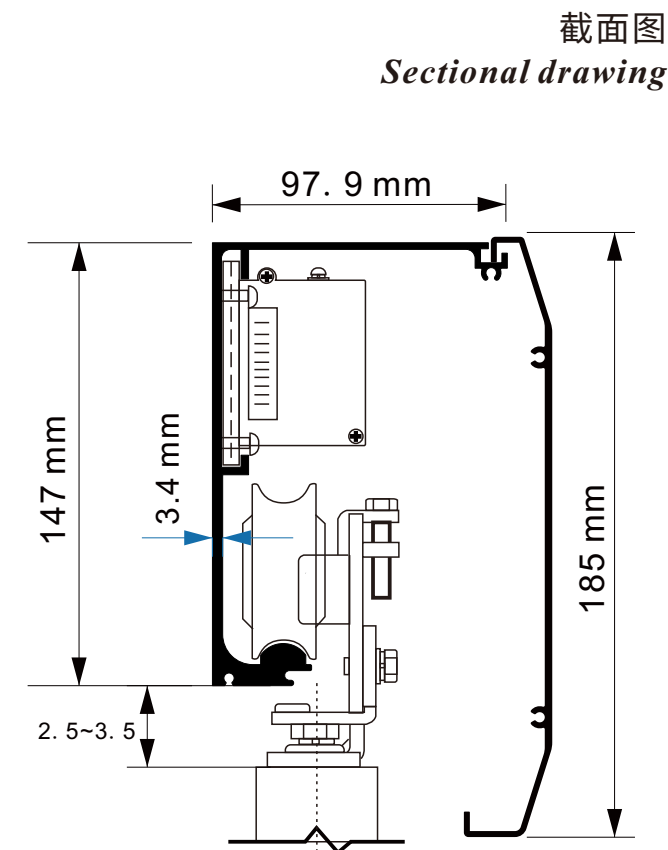



- Intelligent control system, automatically adjust the operating state of the door leaf when starting, automatic learning starts, automatically adjust the parameters according to the actual door width size, in order to achieve the best operating conditions, manual adjustment can be made if necessary.
- Brushless motor (BLDC), low friction, long life.
- The door leaf suspension adopts self-balancing and reliable anti-slip design, making the door leaf run more stable, safe, low noise, and prolonging the service life of the suspension wheel.
- Unique electric lock function, safe and reliable, double door interlock and electronic lock function, support a variety of access control systems.
- Can be equipped with a backup power supply, in the case of power failure can keep the door open and closed.

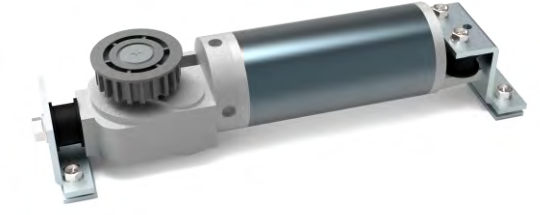

技术参数 PRODUCT PARAMETERS

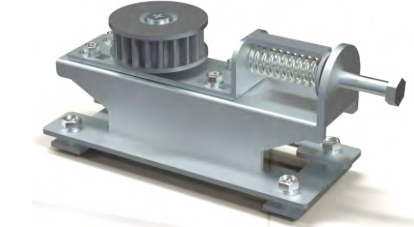
电气数据	Electrical data
电源电压: AC220V±10%, 50-60Hz 2A	Power supply voltage: AC220V ± 10%, 50-60Hz 2A
额定功率: 120W	Rated power: 120W
开口宽度	Opening width
双开平移门: 1000-1500	Double sliding door: 1000 ~ 1500
单开平移门: 1000-2000	Single sliding door: 1000 ~ 2000
门扇重量	Door leaf weight
双开平移门: 最大2×300KG	Double opening sliding door: max. 2 × 300KG
单开平移门: 最大1×400KG	Single sliding door: max. 1 × 400KG
门扇运行速度	Door leaf running speed
开门速度: 150-460mm/s	Opening speed: 150 ~ 460mm / S
关门速度: 150-460mm/s	Closing speed: 150 ~ 460mm / S
环境条件	Environment condition
温度范围: -20℃~+50℃	Temperature range: - 20 °C ~ + 50 °C
湿度范围: <相对湿度85%	Humidity range: < 85% relative humidity

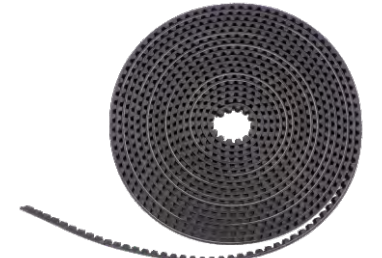
主要配件 MAIN ACCESSORIES

			
控制器 Controller	电机 Motor	轨道 track	尾轮 Pulley
			
吊轮 Hanger	皮带 Belt	遥控器 remote control	

可选配件 MAIN ACCESSORIES

				
防夹光线 Anti pinch equipment	影像感应器 Image sensor	门禁机 Access control machine	门夹 Door clip	备用电源 Backup

ORD-800 自动平移门机组

ORD800 stye Automatic Sliding Door



智能化控制器

加长加厚的轨道

加宽加重的吊轮

大功率直驱电机

Intelligent controller

Lengthened and thickened track

Widened and weighted lifting wheel

High power direct drive motor

实景图 SITE PHOTOS



技术参数 PRODUCT PARAMETERS

电气数据

电源电压: AC220V ± 10%, 50-60Hz 2A

消耗功率: 120W

开口宽度

双开平移门: 800~2500

单开平移门: 700~3000

门扇重量

双开平移门: 最大2 × 350KG

单开平移门: 最大1 × 400KG

门扇运行速度

开门速度: 100~500mm/s

关门速度: 100~400mm/s

环境条件

温度范围: -20°C~+50°C

湿度范围: < 相对湿度85%

Electrical data

Power supply voltage: AC220V ± 10%, 50-60Hz 2A

Rated voltage: 120W

Opening width

Double sliding door: 800 ~ 2500

Single sliding door: 700 ~ 3000

Door leaf weight

Double opening sliding door: max. 2 × 350KG

Single sliding door: max. 1 × 400KG

Door leaf running speed

Opening speed: 100 ~ 500mm / S

Closing speed: 100 ~ 400mm / S

Environment condition







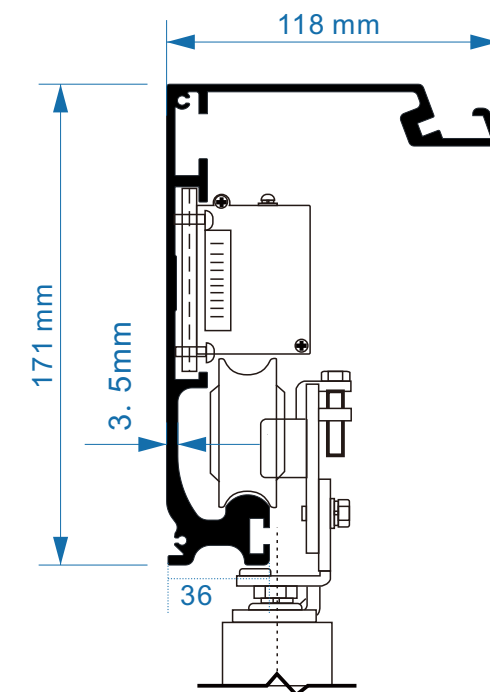

Temperature range: - 20 °C ~ + 50 °C

Humidity range: < 85% relative humidity

截面图 SECTIONAL DRAWING



主要配件 MAIN ACCESSORIES

			
控制器 Controller	电机 Motor	轨道 track	吊轮 Hanger
			
钢丝皮带 Wire Belt	尾轮 Pulley	限位器 Stopper	遥控器 remote control

可选配件 MAIN ACCESSORIES

				
防夹光线 Anti pinch equipment	影像感应器 Image sensor	门禁机 Access control machine	门夹 Door clip	备用电源 Backup

ORD-1000 自动平移门机组

ORD000 stye Automatic Sliding Door



实景图 SITE PHOTOS



技术参数 PRODUCT PARAMETERS

电气数据

电源电压: AC220V ± 10%, 50-60Hz 2A
消耗功率: 180W

开口宽度

双开平移门: 800~2500
单开平移门: 700~3000

门扇重量

双开平移门: 最大 2 × 600KG
单开平移门: 最大 1 × 800KG

门扇运行速度

开门速度: 100~400mm/s
关门速度: 100~350mm/s

环境条件

温度范围: -20°C ~ +60°C
湿度范围: < 相对湿度 85%

Electrical data

Power supply voltage: AC220V ± 10%, 50-60Hz 2A
Rated voltage: 180W

Opening width

Double sliding door: 800 ~ 2500
Single sliding door: 700 ~ 3000

Door leaf weight

Double opening sliding door: max. 2 × 600KG
Single sliding door: max. 1 × 800KG

Door leaf running speed

Opening speed: 100 ~ 400mm / S
Closing speed: 100 ~ 350mm / S



Environment condition

Temperature range: - 20 °C ~ + 60 °C
Humidity range: < 85% relative humidity

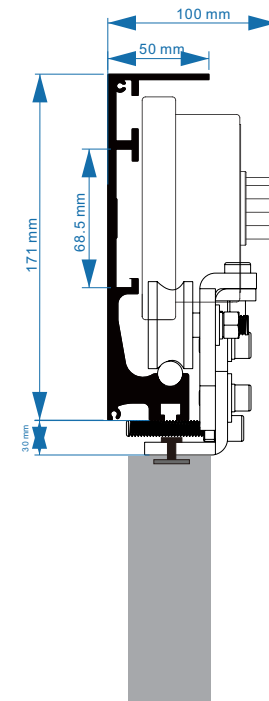
截面 SECTIONAL DRAWING

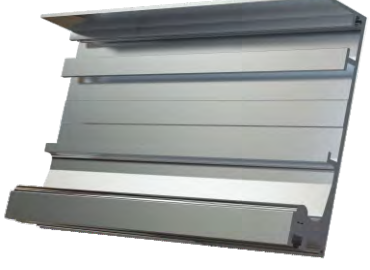

主要配件 MAIN ACCESSORIES

			
控制器 Controller	电机 Motor	轨道 track	吊轮 Hanger
			
钢丝皮带 Wire Belt	尾轮 Pulley	限位器 Stopper	遥控器 remote control

可选配件 MAIN ACCESSORIES

				
防夹光线 Anti pinch equipment	影像感应器 Image sensor	门禁机 Access control machine	门夹 Door clip	备用电源 Backup