



04

PART FOUR

自动平开门系列

Automatic Door Opening Machine Series

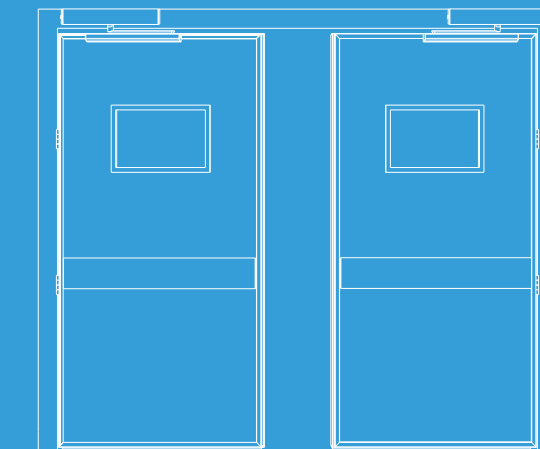

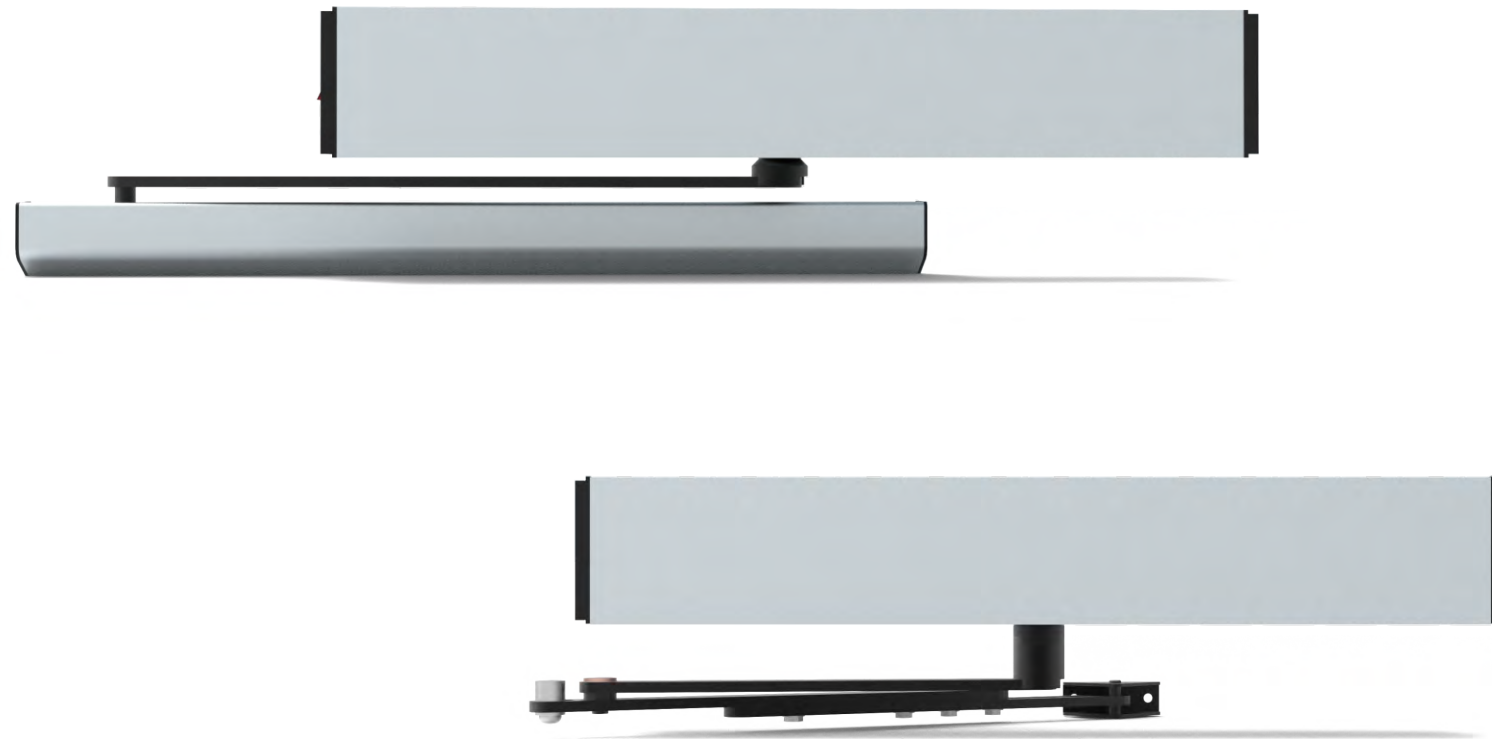

ORD-100/DSW-100 90度平开门机组 POTENTIOMETER AUTOMATIC SWING DOOR UNIT

产品特点 PRODUCT FEATURES

1. 控制器和变压器组合更节省空间。
 2. 传感器可内外直接连接,互不干扰。
 3. 可以直接连接磁力锁。
 4. 支持双门联动和双门互锁
1. The combination of controller and transformer saves space.
 2. The sensor can be directly connected inside and outside without interference.
 3. The magnetic lock can be directly connected.
 4. Support double door linkage and double door interlock

技术参数 PRODUCT PARAMETERS

型号	Model number	DSW-100	DSW-100A
单门承重	Single door bearing	100kg	110kg
门体宽度	Door width	≤1.5m	≤1.5m
电源输入	Power input	220V	220V
电 锁	Electric lock	可接 available	可接 available
闭合力	Closing force	≤30kg	≤30kg
开门角度	Opening Angle	60°~110°可调 (adjustable)	60°~110°可调 (adjustable)
开启时间	Opening time	3~7s可调 (adjustable)	3~7s可调 (adjustable)
开门保持	Open hold	1~30s	1~30s
工作温度	Operating temperature	-20°C~+50°C	-20°C~+50°C
测试寿命	Test life	百万次 (million times)	百万次 (million times)

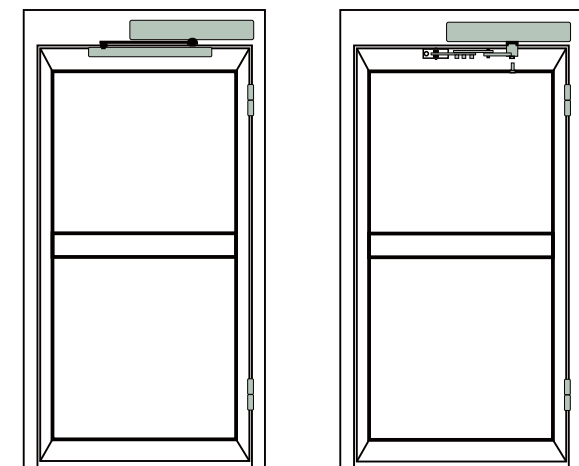
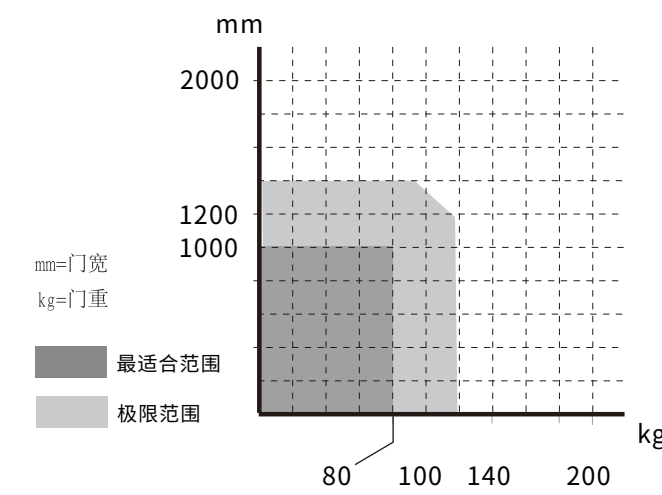

内部区别 INTERNAL DISTINCTION

DSW100A



DSW-100



配件尺寸/ Fitting size

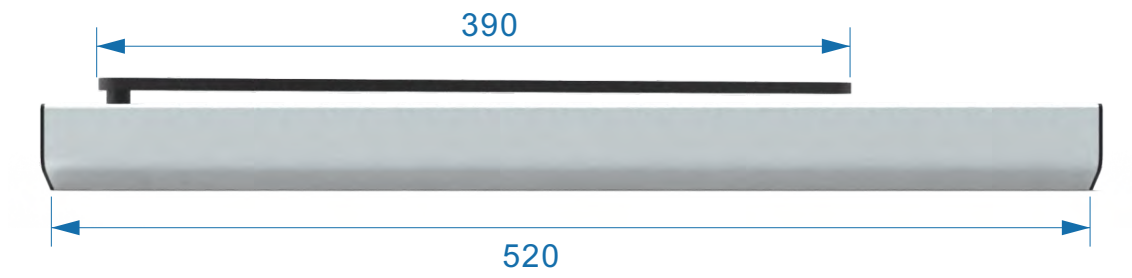

可选配件 MAIN ACCESSORIES



防夹光线 Anti pinch equipment



影像感应器 Image sensor



门禁机 Access control machine



电控锁 Electric control lock



备用电源 Backup



DSW-100E 90度平开门机组 POTENTIOMETER AUTOMATIC SWING DOOR UNIT

产品特点 PRODUCT FEATURES

1. 高品质电源用料,符合不同国家电源标准
2. 支持110V-240V电压,适用范围广。
3. 标准无刷直流电机,运行静音;
4. 遇阻反弹,安全防夹;

1. High quality power supply materials.
2. Support 110V-240V voltage, wide application range.
3. Standard brushless DC motor, quiet operation;
4. Resist rebound, safety anti-clamp;

技术参数 PRODUCT PARAMETERS

尺寸	550*55*83
重量	7KG
工作温度	-20~60°C
输入电压	AC100V-240V 50-60Hz
输出电压	24VDC(±10%),3A
最大开启角度	Max99°
开关门速度	45°/S
开门时间	0-60S(可调)
防护等级	IP21
最大承重	100kg

size	550*55*83
weight	7KG
Operating temperature	-20~60°C
Input voltage	AC100V-240V 50-60Hz
Output voltage	24VDC(±10%),3A
Max opening Angle	Max99°
Opening/closing speed	45°/S
Opening time	0-60S(adjustable)
Class of protection	IP21
Max door weight	100kg

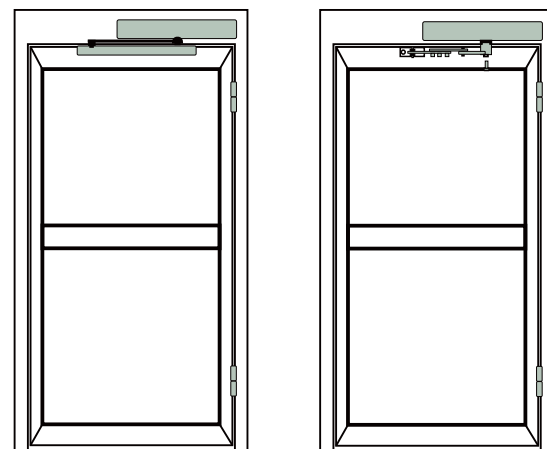
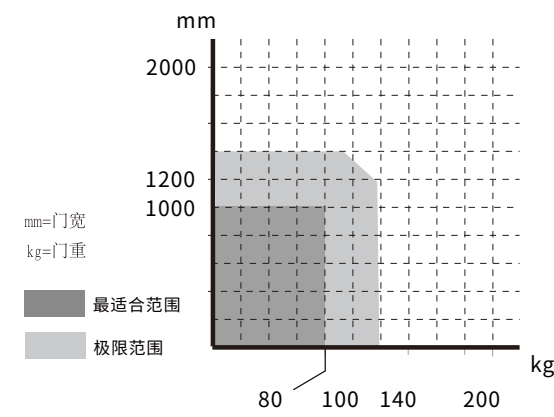

主机配件 / Optional component



可选配件 MAIN ACCESSORIES



详细尺寸/ Detailed dimension

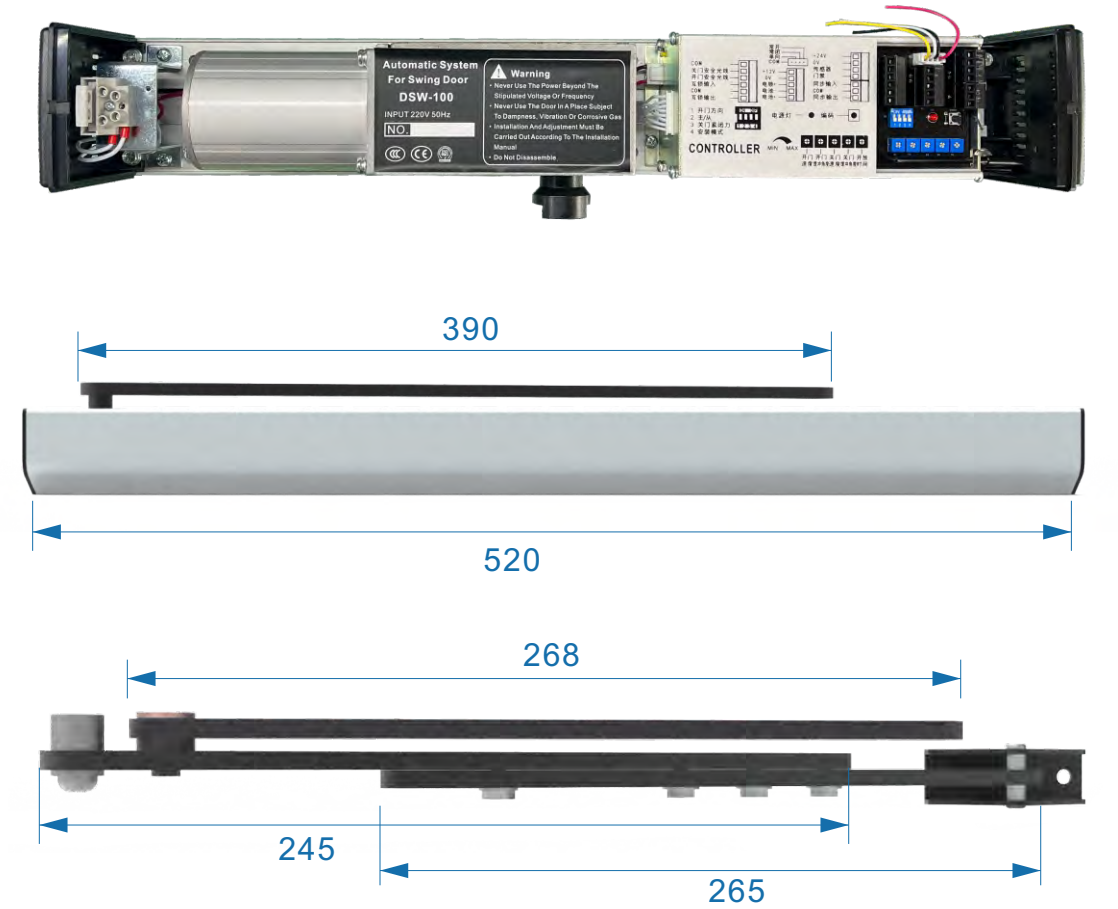



技术参数 PRODUCT PARAMETERS

驱动单元	Driving unit	24DCmotor
电源电压	Supply voltage	AC100V-240V, 50-60Hz
额定功耗	Rated power consumption	100W(MAX)
开启时间(速度)	Opening time (speed)	3-7S/90°(adjustable)
关闭时间(速度)	Closing time (speed)	3-7S/90°(adjustable)
开放时间	Opening hours	0.5~30S(adjustable)
开启角	Opening Angle	80°~100°
驱动臂	Driving arm	推臂/滑臂
环境温度	Ambient temperature	-20~+45°C
相对湿度	Relative humidity	≤85%

DSW-150
电动闭门器
POTENTIOMETER AUTOMATIC SWING DOOR UNIT

产品特点 PRODUCT FEATURES

1. 高品质电源用料,符合不同国家电源标准
2. 支持110V-240V电压,适用范围广。
3. 标准无刷直流电机,运行静音;
4. 遇阻反弹,安全防夹;

1. High quality power supply materials.
2. Support 110V-240V voltage, wide application range.
3. Standard brushless DC motor, quiet operation;
4. Resist rebound, safety anti-clamp;

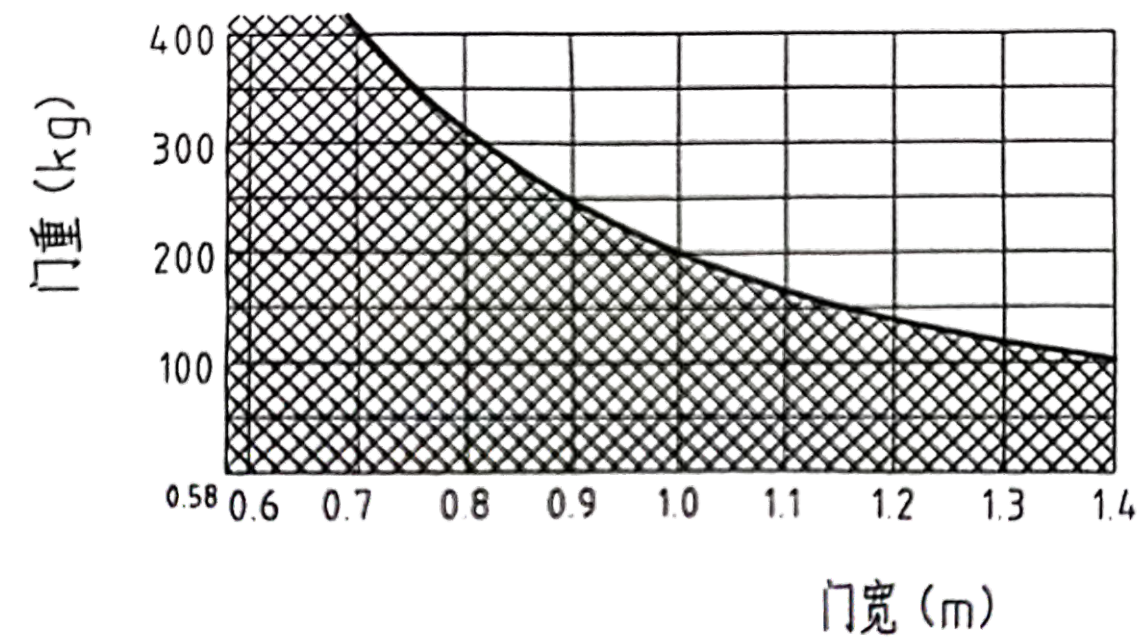

主机配件 / Optional component



详细尺寸 / Detailed dimension

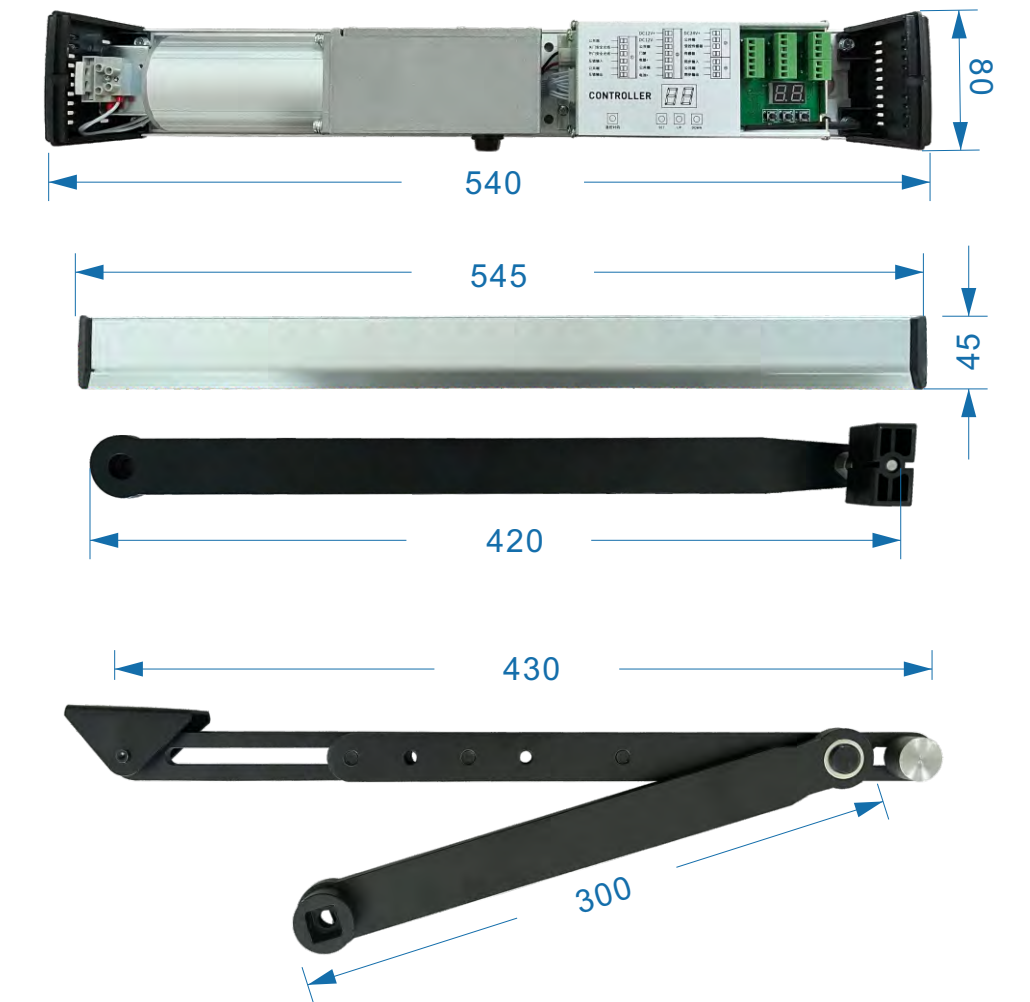

可选配件 MAIN ACCESSORIES



防夹光线 Anti pinch equipment

影像感应器 Image sensor

门禁机 Access control machine

电控锁 Electric control lock

备用电源 Backup

SW-200A 小型平开门机组 SMALL SWING DOOR UNIT

产品特点 PRODUCT FEATURES

1. 新一代无刷直流电机, 运行静音;
 2. 全金属铝合金外壳, 更美观;
 3. 迷你型平开门尺寸, 所需安装空间更小。
1. A new generation of brushless DC motor, quiet operation;
 2. All-metal aluminum alloy shell, more beautiful;
 3. Mini flat door size, required installation space is smaller.



技术参数 PRODUCT PARAMETERS

尺寸	size	550*74*81
重量	weight	15KG
工作温度	Operating temperature	-20~60°C
输入电压	Input voltage	AC100V-240V 50-60Hz
输出电压	Output voltage	24VDC(±10%),3A
最大开启角度	Max opening Angle	Max99°
开关门速度	Opening/closing speed	45°/S
开门时间	Opening time	0-60S(adjustable)
防护等级	Class of protection	IP21
最大承重	Max door weight	100kg

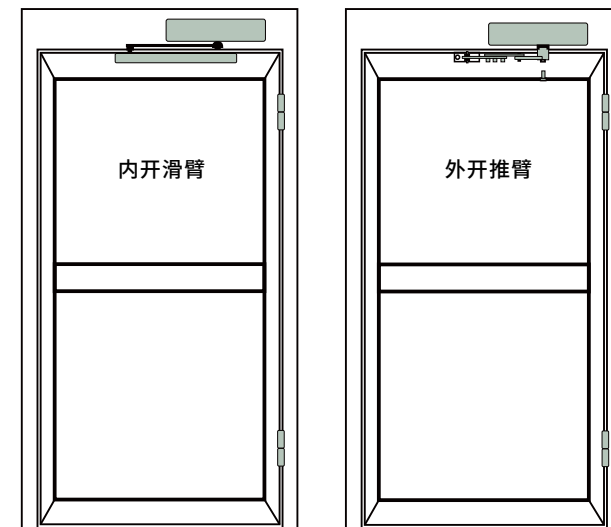

尺寸对比 Size comparison

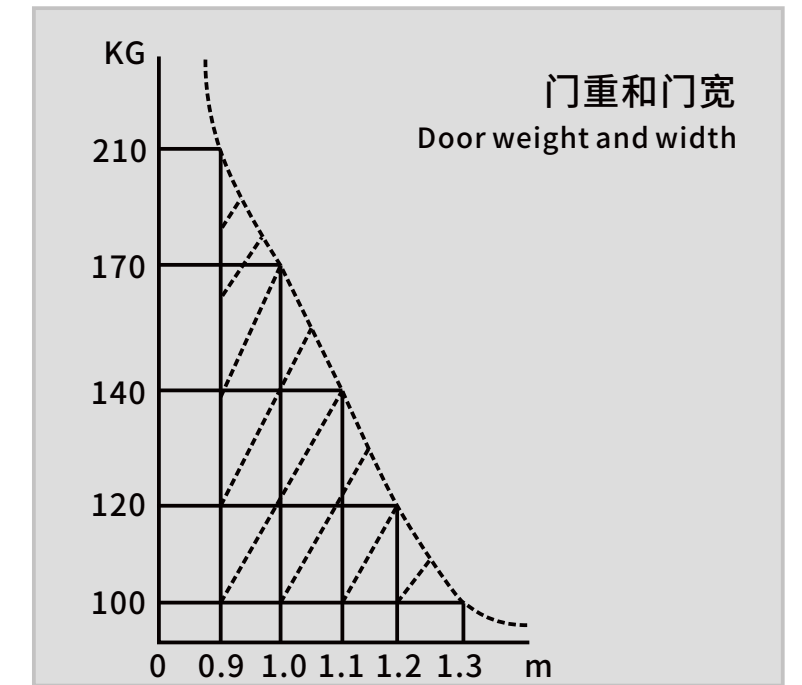
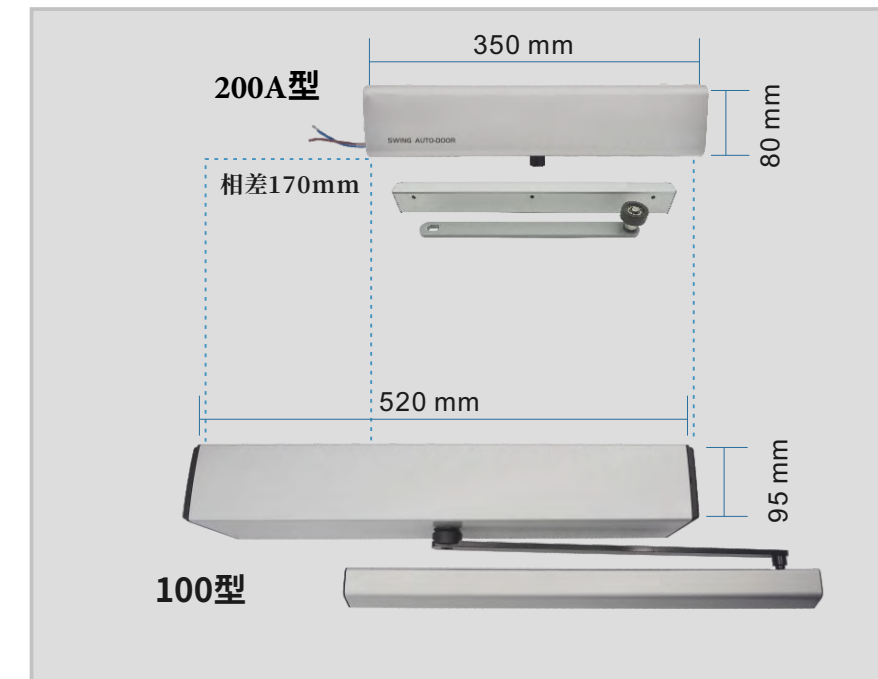

主机配件 / Optional component

拉杆/往内开

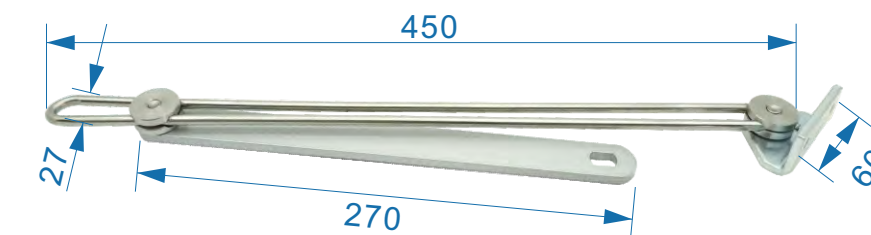

推杆/往外开

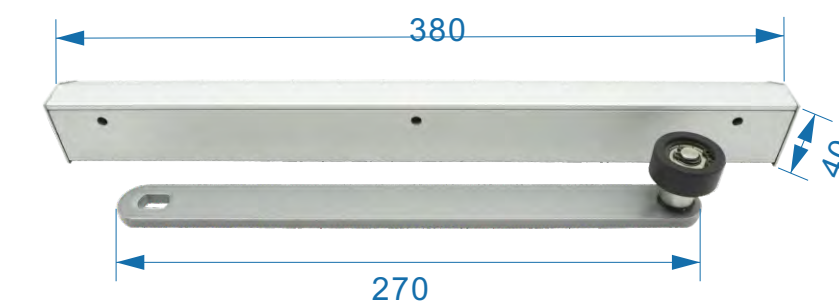

可选配件 MAIN ACCESSORIES

 防夹光线 Anti pinch equipment	 影像感应器 Image sensor	 门禁机 Access control machine
 电控锁 Electric control lock	 备用电源 Backup	 密码刷卡器 Cipher disk

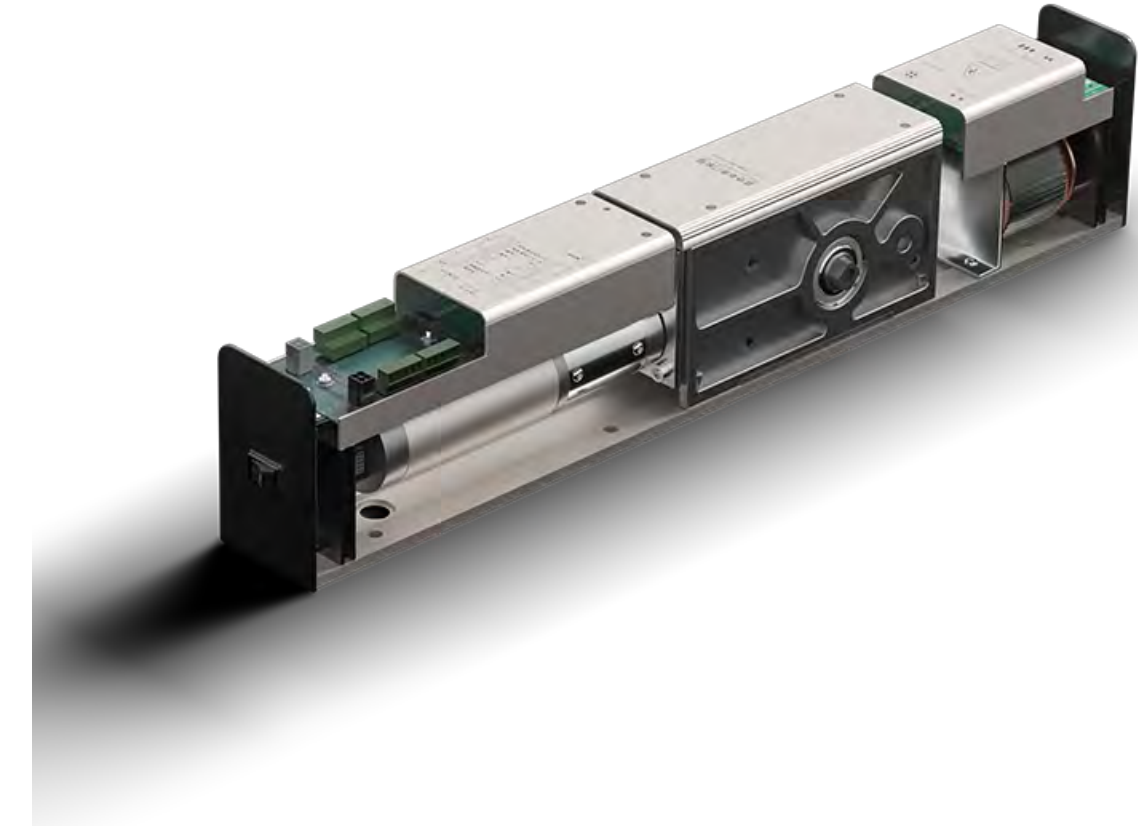

SW-500A 重型平开门机组

SW-500 HEAVY DUTY FLAT DOOR OPENING UNIT

产品特点 PRODUCT FEATURES

1. 轻便美观, 方榫与端面花键齿完美结合门体运行更顺畅;
2. 干接点接口, 可搭配多种开门方式;
3. 重型平开门, 1.2米门体可承重170KG。

1. Light and beautiful, square tenon and end face tooth perfect combination of the door body running more smoothly;
2. Dry contact interface, can be matched with a variety of door opening methods;
3. Heavy flat door, 1.2m door body can bear 170KG.

技术参数 PRODUCT PARAMETERS

驱动单元	Driving unit	24DCmotor
电源电压	Supply voltage	AC220V±10%, 50-60Hz
额定功耗	Rated power consumption	100W(MAX)
开启时间(速度)	Opening time (speed)	3-7S(adjustable)
关闭时间(速度)	Closing time (speed)	3-7S(adjustable)
开放时间	Opening hours	0.5~30S(adjustable)
开启角	Opening Angle	80°~100°
驱动臂	Driving arm	推臂/滑臂
环境温度	Ambient temperature	-20~+45°C
相对湿度	Relative humidity	≤85%

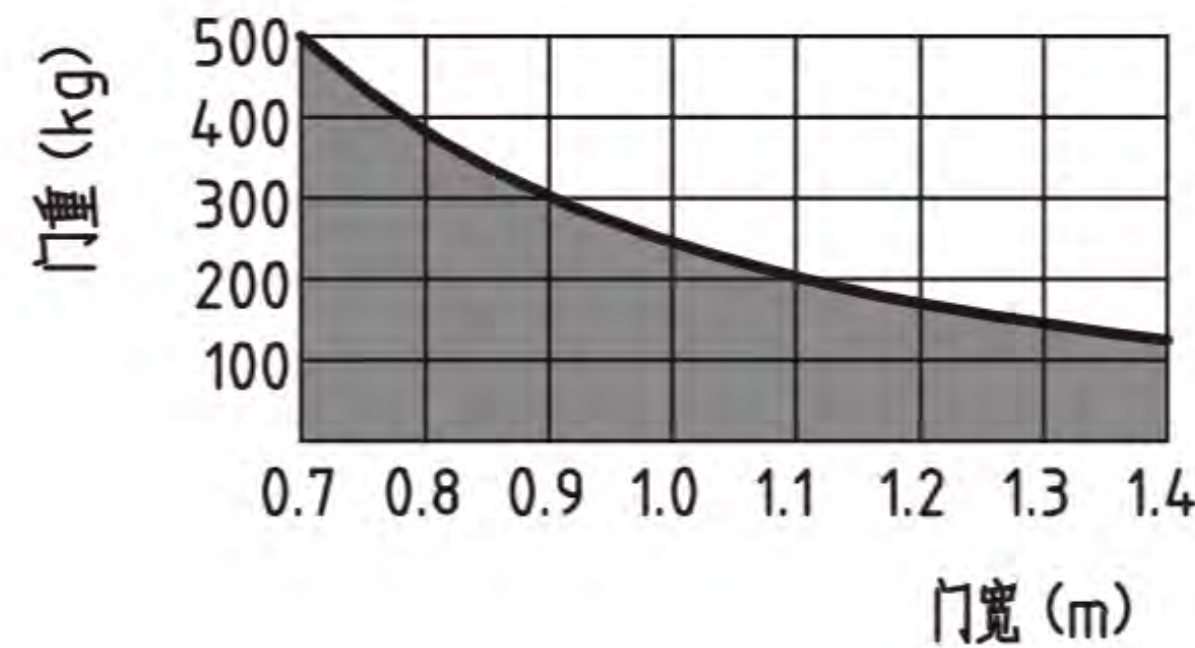

配置清单 CONFIGURATION LIST



可选配件 MAIN ACCESSORIES

